

**RAISED ACCESS
FLOORS**

PAVIMENTI TECNICI
SOPRAELEVATI

INTERIOR FIT-OUT EVOLUTION

raised access floors

metal ceilings & coverings

wood ceilings & coverings

demountable partitions

suspension systems

integrated air conditioning systems

office furniture systems

The person, at the center.

CBI Europe has produced technological and innovative systems for a complete interior installation, with passion and precision, for forty years, worldwide.

The technical experience and the continuous comparison, with the demands of designers from different markets, make CBI EUROPE an ideal reference point for those who design new, refined and comfortable interiors, and at the same time CBI EUROPE is technologically advanced in an integrated context, offering a very wide range of systems, products, materials, technical solutions and alternatives that improve work environments of the latest generation. We are committed to creating healthy and socially responsible environments. With our continuous research of new materials and systems, the international competition and comparison, awareness of needing to evolve the dynamics of modern construction techniques and to solve traditional problems.

CBI Europe says today, these methods; technique, creativity and Italian style promote an interior of the third millennium, worldwide.

**The future is to ensure the quality
of the environment in which we live.**

La persona, al centro.

CBI Europe produce con passione e precisione sistemi innovativi e tecnologici per l'allestimento completo d'interni, da oltre quarant'anni in tutto il mondo.

L'esperienza tecnica maturata e il confronto continuo con le esigenze di progettisti di diversi mercati fanno di CBI EUROPE un riferimento unico ideale per chi progetta interni nuovi, ricercati, confortevoli al tempo stesso tecnologicamente avanzati in ottica integrata, proponendo una gamma molto ampia di sistemi, prodotti, materiali e soluzioni tecniche alternative e migliorative per ambienti di ultima generazione.

Impegno per la creazione di ambienti sani e socialmente responsabili, ricerca continua di materiali e nuovi sistemi, competizione e confronto internazionale, consapevolezza dell'esigenza di evolvere le dinamiche delle moderne tecniche costruttive per risolvere le problematiche tradizionali sono i metodi con cui CBI Europe, oggi, afferma la tecnica, la creatività e lo stile italiano nel mondo e promuove un'edilizia per interni di terzo millennio.

**Il futuro è garantire la qualità
degli interni in cui viviamo.**

modular

durable

resistant

easy to handle

quick to install

inspectable

certified

ecofriendly

designed for new

generation interiors

40 YEAR EXPERIENCE WORLDWIDE

RAISED ACCESS FLOORS

PAVIMENTI TECNICI SOPRAELEVATI

panels	
pannelli	7
factory finished panels <i>pannelli con rivestimento pronti per l'installazione</i>	8
bare panels <i>pannelli senza finitura</i>	13
structures	
strutture	22
floor system <i>strutture per pavimenti tecnici</i>	22
finishes	
finiture	27
hard coverings <i>hard coverings</i>	27
soft coverings <i>soft coverings</i>	32
special systems	
sistemi speciali	42
cable management system <i>sistema ispezionabile cable management</i>	42
metal air steel panels <i>pannelli in acciaio metal air</i>	43
accessories	
accessori	46
accessories <i>accessories</i>	46
incidence <i>incidenza</i>	48
recommendations for installation <i>raccomandazioni per l'installazione</i>	49

HIGHLIGHTS

where

New-build and refurbished offices, banks, operations centres, control rooms, hospitals, homes and public buildings.

how

Using easy access, inspectable panel structures to create high-tech raised floors in a wide range of types and finishes.

why

CBI Europe's integrated floor systems are versatile, high-tech, sustainable, easy to install and inspect, and the perfect solution for all types of structural and design requirements.

dove

Realizzazioni o ristrutturazioni di uffici, banche, sale quadri, ospedali, abitazioni residenziali e locali pubblici.

come

Strutture sopraelevate tecnologicamente avanzate e pannelli accessibili ed ispezionabili in varie tipologie e finiture.

perchè

Versatili, tecnologici, ecosostenibili, facili da installare ed accessibili in qualsiasi momento, i sistemi integrati Floors sono la risposta per ogni tipo di esigenza realizzativa e progettuale.



MOISTURE RESISTANCE
RESISTENZA ALL'UMIDITÀ



EXTENDED WORKING LIFE
DURABILITÀ



HIGH TRAFFIC RESISTANCE
ALTA RESISTENZA AL CALPESTIO



LOAD BEARING RESISTANCE
RESISTENZA AL CARICO



QUICK INSTALLATION
INSTALLAZIONE RAPIDA



INSPECTABILITY
ISPEZIONABILITÀ



100%
MADE IN ITALY



EUROCLASS A1 · Bfl-s1
REI 30 · REI 60



ACOUSTIC ABSORPTION
FONOASSORBENZA



POINTS LEED
PUNTEGGIO LEED



EPD ENVIRONMENTAL
PRODUCT DECLARATION®



EUROFINS
INDOOR AIR COMFORT GOLD

TYPE OF PANELS TIPOLOGIA DI PANNELLI

FACTORY FINISHED PANELS

PANNELLI CON RIVESTIMENTO PRONTI PER L'INSTALLAZIONE

woodcore panels pannelli in conglomerato ligneo 	soft coverings	aluminum foil backing lamina di alluminio galvanized steel dish vaschetta di acciaio zincato	PT30 · PT38 PT30V · PT38V
	hard coverings	aluminum foil backing lamina di alluminio	PT30C · PT38C
calcium sulphate panels pannelli in solfato di calcio 	soft coverings	galvanized steel dish vaschetta di acciaio zincato	SC30V · SC33V · SC36V SC36VHD
	hard coverings	aluminum foil backing lamina di alluminio	SC30C

BARE PANELS

PANNELLI SENZA FINITURA

woodcore panels pannelli in conglomerato ligneo 	gravity lay	semi-encapsulated steel semi-incapsulato in acciaio fully steel encapsulated incapsulato in acciaio	CBI28T · CBI30T CBL1 · CBH
	corner lock	fully steel encapsulated incapsulato in acciaio	CBL1 · CBH
calcium sulphate panels pannelli in solfato di calcio 	gravity lay	semi-encapsulated steel semi-incapsulato in acciaio fully steel encapsulated incapsulato in acciaio	CBI28S · CBI31S CBL1/S · CBM/S · CBH/S
	corner lock	fully steel encapsulated incapsulato in acciaio	CBL1/S CORNER LOCK CBH/S CORNER LOCK
	tongue&groove	galvanized steel dish vaschetta di acciaio zincato	CBI30TG · CBI36TG
hybrid panels woodcore + calcium sulphate conglomerato ligneo + solfato di calcio 	gravity lay	semi-encapsulated steel semi-incapsulato in acciaio fully steel encapsulated incapsulato in acciaio	CBI28-HYBRID CBI30-HYBRID

WOODCORE PANELS › ALUFOIL BACKING · SOFT COVERINGS

PANNELLO IN CONGLOMERATO LIGNEO CON LAMINA DI ALLUMINIO · SOFT COVERINGS

woodcore high density conglomerato ligneo 600 x 600 mm



aluminum foil backing lamina di alluminio 0.05 mm

soft coverings: alufoil, HPL, PVC, linoleum, rubber, parquet

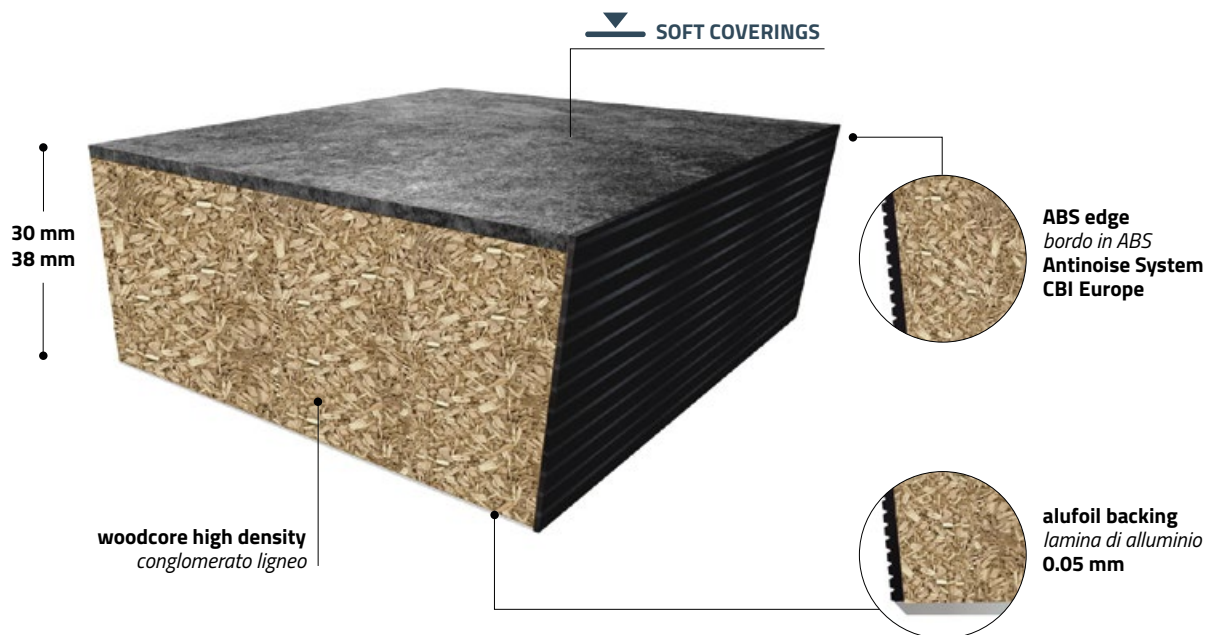
soft coverings: lamina di alluminio, HPL, PVC, linoleum, gomma, parquet



TECHNICAL SPECIFICATIONS	PT30 h 30 mm / kg 7,60	PT38 h 38 mm / kg 10,00
fire reaction UNI EN 13501-1	Bfl-s1	
fire resistance UNI EN 13501-2	REI 30	
EPD® registration number	S-P-03624	

TECHNICAL FEATURES UNI EN 12825		
 CBI/ST	center of panel - deflection 2,5 mm	3,2 › 4,0 KN
	center of panel - ultimate load	9,0 › 11,5 KN
	loading class	4 › 5
 CBI/CR	center of panel - deflection 2,5 mm	3,3 › 4,2 KN
	center of panel - ultimate load	9,5 › 12,0 KN
	loading class	4 › 6
 IF tubular	center of panel - deflection 2,5 mm	3,5 › 4,4 KN
	center of panel - ultimate load	10,0 › 12,6 KN
	loading class	5 › 6



EN The load resistance tests have been performed in CBI Europe's internal laboratory and simulate the test method indicated by UNI EN 12825: 2001. The results obtained at a height of 20 cm may vary depending on the installation and the general conditions of the site. If the project requires a certification from a third party this must be explicitly requested. **IT** Le prove di resistenza al carico non sono state eseguite nel laboratorio interno CBI Europe e simulano il metodo di prova indicato dalla normativa UNI EN 12825:2001. I risultati ottenuti ad un'altezza di 20 cm possono variare in funzione dell'installazione e delle condizioni generali del cantiere. Qualora il progetto richieda una certificazione da un ente terzo questa dovrà essere espressamente richiesta.

FACTORY FINISHED PANELS

WOODCORE PANELS › GALVANIZED STEEL DISH · SOFT COVERINGS*PANNELLO IN CONGLOMERATO LIGNEO CON VASCHETTA IN ACCIAIO ZINCATO · SOFT COVERINGS***woodcore high density** *conglomerato ligneo 600 x 600 mm***galvanized steel** *acciaio zincato 0.5 mm***soft coverings:** *alufoil, HPL, PVC, linoleum, rubber, parquet**soft coverings: lamina di alluminio, HPL, PVC, linoleum, gomma, parquet*

TECHNICAL SPECIFICATIONS	PT30V h 30,5 mm / kg 9,00	PT38V h 38,5 mm / kg 11,50
fire reaction UNI EN 13501-1	Bfl-s1	
fire resistance UNI EN 13501-2	REI 30	
EPD® registration number	S-P-03625	S-P-03626

TECHNICAL FEATURES UNI EN 12825

CBI/ST 	center of panel - deflection 2,5 mm	3,5 > 5,5 KN
	center of panel - ultimate load	10,6 > 14,5 KN
	loading class	5 > 6
CBI/CR 	center of panel - deflection 2,5 mm	3,6 > 5,8 KN
	center of panel - ultimate load	11,2 > 15,2 KN
	loading class	5 > 6
IF tubolar 	center of panel - deflection 2,5 mm	3,9 > 6,1 KN
	center of panel - ultimate load	11,8 > 16,0 KN
	loading class	5 > 6

EN The load resistance tests have been performed in CBI Europe's internal laboratory and simulate the test method indicated by UNI EN 12825: 2001. The results obtained at a height of 20 cm may vary depending on the installation and the general conditions of the site. If the project requires a certification from a third party this must be explicitly requested. **IT** Le prove di resistenza al carico sono state eseguite nel laboratorio interno CBI Europe e simulano il metodo di prova indicato dalla normativa UNI EN 12825:2001. I risultati ottenuti ad un'altezza di 20 cm possono variare in funzione dell'installazione e delle condizioni generali del cantiere. Qualora il progetto richieda una certificazione da un ente terzo questa dovrà essere espressamente richiesta.

WOODCORE PANELS › ALUFOIL BACKING · HARD COVERINGS

PANNELLO IN CONGLOMERATO LIGNEO CON LAMINA DI ALLUMINIO · HARD COVERINGS

woodcore high density conglomerato ligneo 600 x 600 mm

aluminum foil backing lamina di alluminio 0.05 mm



hard coverings: ceramic tiles

hard coverings: gres



TECHNICAL SPECIFICATIONS	PT30C h 30 mm / kg 16,70	PT38C h 38 mm / kg 19,00
fire reaction UNI EN 13501-1	Bfl-s1	
fire resistance UNI EN 13501-2	REI 30	
EPD® registration number	S-P-03624	

TECHNICAL FEATURES UNI EN 12825

 CBI/ST	center of panel - deflection 2,5 mm	6,75 > 7,1 kn
	center of panel - ultimate load	13,4 > 14,1 kn
	loading class	6
 CBI/CR	center of panel - deflection 2,5 mm	7,0 > 7,4 kn
	center of panel - ultimate load	14,0 > 14,8 kn
	loading class	6
 IF tubular	center of panel - deflection 2,5 mm	7,41 > 7,8 kn
	center of panel - ultimate load	14,8 > 15,5 kn
	loading class	6

EN The load resistance tests have been performed in CBI Europe's internal laboratory and simulate the test method indicated by UNI EN 12825: 2001. The results obtained at a height of 20 cm may vary depending on the installation and the general conditions of the site. If the project requires a certification from a third party this must be explicitly requested. **IT** Le prove di resistenza al carico non sono state eseguite nel laboratorio interno CBI Europe e simulano il metodo di prova indicato dalla normativa UNI EN 12825:2001. I risultati ottenuti ad un'altezza di 20 cm possono variare in funzione dell'installazione e delle condizioni generali del cantiere. Qualora il progetto richieda una certificazione da un ente terzo questa dovrà essere espressamente richiesta.

FACTORY FINISHED PANELS

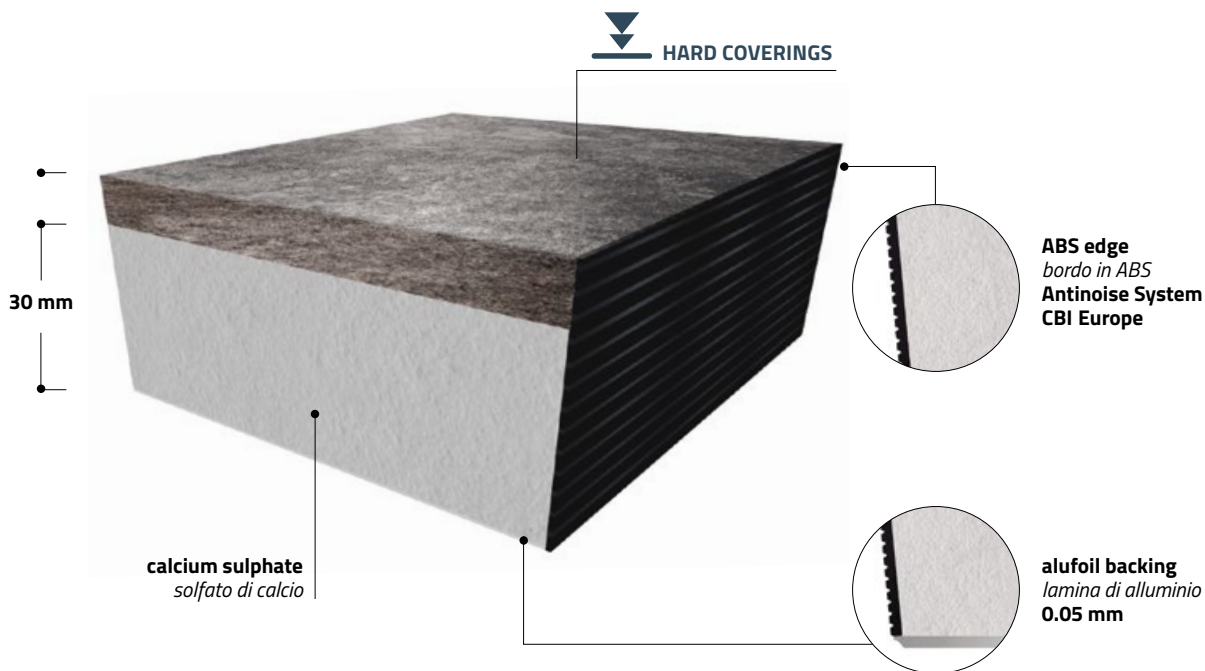
CALCIUM SULPHATE PANELS › ALUFOIL BACKING · HARD COVERINGS*PANNELLO IN SOLFATO DI CALCIO CON LAMINA DI ALLUMINIO · HARD COVERINGS***calcium sulphate** *solfo di calcio* **600 x 600 mm****aluminum foil backing** *lamina di alluminio* **0.05 mm****hard coverings: ceramic tiles***hard coverings: gres*

TECHNICAL SPECIFICATIONS		SC30C h 30 mm / kg 22,00
fire reaction UNI EN 13501-1		A1
fire resistance UNI EN 13501-2		REI 30
EPD® registration number		S-P-03627

TECHNICAL FEATURES UNI EN 12825

	center of panel - deflection 2,5 mm	6,2 KN
	center of panel - ultimate load	8,1 KN
	loading class	3
	center of panel - deflection 2,5 mm	6,5 KN
	center of panel - ultimate load	8,5 KN
	loading class	3
	center of panel - deflection 2,5 mm	6,8 KN
	center of panel - ultimate load	8,9 KN
	loading class	3

EN The load resistance tests have been performed in CBI Europe's internal laboratory and simulate the test method indicated by UNI EN 12825: 2001. The results obtained at a height of 20 cm may vary depending on the installation and the general conditions of the site. If the project requires a certification from a third party this must be explicitly requested. **IT** Le prove di resistenza al carico sono state eseguite nel laboratorio interno CBI Europe e simulano il metodo di prova indicato dalla normativa UNI EN 12825:2001. I risultati ottenuti ad un'altezza di 20 cm possono variare in funzione dell'installazione e delle condizioni generali del cantiere. Qualora il progetto richieda una certificazione da un ente terzo questa dovrà essere espressamente richiesta.

CALCIUM SULPHATE PANELS › GALVANIZED STEEL DISH · SOFT COVERINGS

PANNELLO IN SOLFATO DI CALCIO CON VASCHETTA IN ACCIAIO ZINCATO · SOFT COVERINGS



calcium sulphate *solfato di calcio* 600 x 600 mm

galvanized steel *acciaio zincato* 0.5 mm

soft coverings: alufoil, HPL, PVC, linoleum, rubber, parquet

soft coverings: lamina di alluminio, HPL, PVC, linoleum, gomma, parquet



TECHNICAL SPECIFICATIONS	STANDARD DENSITY PANELS			HIGH DENSITY PANELS · DATA CENTER USE
	SC30V h 30,5 mm kg 14,50	SC33V h 33,5 mm kg 16,00	SC36V h 36,5 mm kg 17,00	SC36VHD h 36,5 mm kg 22,50
fire reaction UNI EN 13501-1	A1			
fire resistance UNI EN 13501-2	REI 30			> REI 60 <
EPD® registration number	S-P-03628			
TECHNICAL FEATURES UNI EN 12825				
 CBI/ST	center of panel - deflection 2,5 mm	4,7 > 5,6 KN		5,9 KN
	center of panel - ultimate load	9,7 > 11,2 KN		17,5 KN
	loading class	4 > 5		6
 CBI/CR	center of panel - deflection 2,5 mm	4,9 > 5,9 KN		6,1 KN
	center of panel - ultimate load	10,2 > 11,8 KN		19,3 KN
	loading class	5		6
 IF tubular	center of panel - deflection 2,5 mm	5,2 > 6,2 KN		6,4 KN
	center of panel - ultimate load	10,7 > 12,3 KN		20,2 KN
	loading class	5 > 6		6

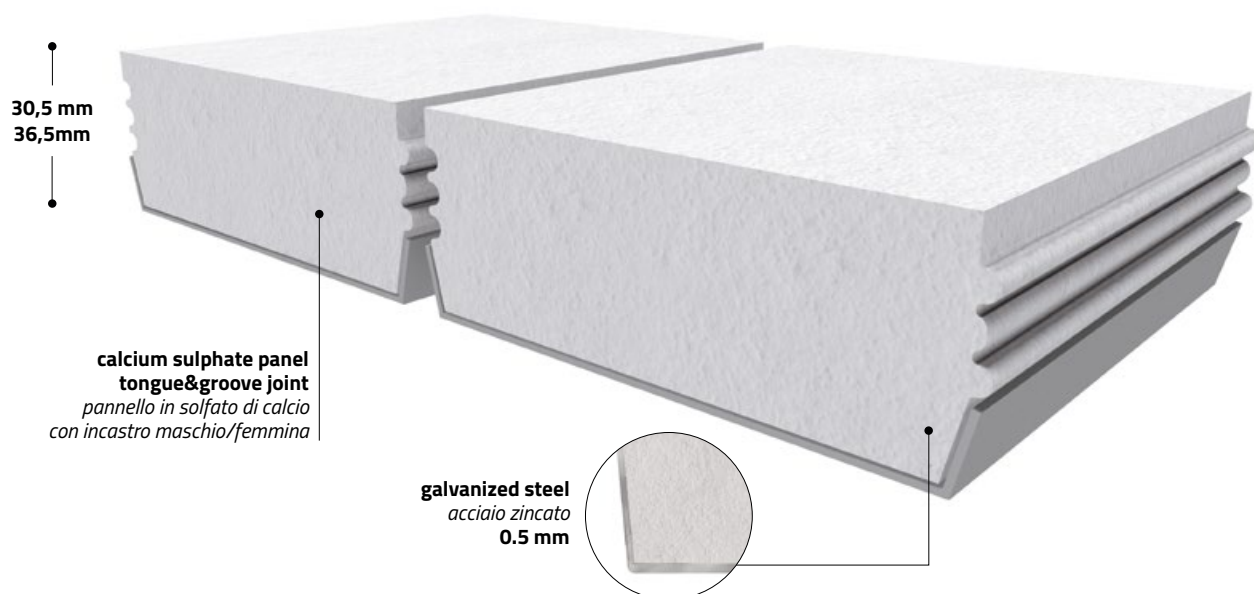

EN The load resistance tests have been performed in CBI Europe's internal laboratory and simulate the test method indicated by UNI EN 12825: 2001. The results obtained at a height of 20 cm may vary depending on the installation and the general conditions of the site. If the project requires a certification from a third party this must be explicitly requested. **IT** Le prove di resistenza al carico sono state eseguite nel laboratorio interno CBI Europe e simulano il metodo di prova indicato dalla normativa UNI EN 12825:2001. I risultati ottenuti ad un'altezza di 20 cm possono variare in funzione dell'installazione e delle condizioni generali del cantiere. Qualora il progetto richieda una certificazione da un ente terzo questa dovrà essere espressamente richiesta.

BARE PANELS

CALCIUM SULPHATE PANELS › TONGUE & GROOVE**PANNELLO IN SOLFATO DI CALCIO TONGUE&GROOVE****calcium sulphate high density** *sofato di calcio ad alta densità* **600 x 600 mm****galvanized steel** *acciaio zincato* **0.5 mm****covering: PVC rubber, linoleum, carpet, ceramic tiles, marble, granite, parquet.***rivestimento superiore: PVC, linoleum, moquette, gres porcellanato, marmo, granito, parquet*

TECHNICAL SPECIFICATIONS	CBI30TG	CBI36TG
	h 30,5 mm / kg 14,50	h 36,5 mm / kg 17,00
fire reaction UNI EN 13501-1	A1	
fire resistance UNI EN 13501-2	> REI 60 <	
EPD® registration number	S-P-03629	

TECHNICAL FEATURES UNI EN 12825

CBI/ST 	center of panel - deflection 2,5 mm	4,7 › 5,6 kn
	center of panel - ultimate load	9,7 › 11,2 kn
	loading class	4 › 5
CBI/CR 	center of panel - deflection 2,5 mm	4,8 › 5,9 kn
	center of panel - ultimate load	9,8 › 11,8 kn
	loading class	4 › 5
IF tubular 	center of panel - deflection 2,5 mm	5,2 › 6,2 kn
	center of panel - ultimate load	10,7 › 12,3 kn
	loading class	5 › 6

EN The load resistance tests have been performed in CBI Europe's internal laboratory and simulate the test method indicated by UNI EN 12825: 2001. The results obtained at a height of 20 cm may vary depending on the installation and the general conditions of the site. If the project requires a certification from a third party this must be explicitly requested. **IT** Le prove di resistenza al carico sono state eseguite nel laboratorio interno CBI Europe e simulano il metodo di prova indicato dalla normativa UNI EN 12825:2001. I risultati ottenuti ad un'altezza di 20 cm possono variare in funzione dell'installazione e delle condizioni generali del cantiere. Qualora il progetto richieda una certificazione da un ente terzo questa dovrà essere espressamente richiesta.

WOODCORE PANELS › FULLY STEEL ENCAPSULATED

PANNELLO IN CONGLOMERATO LIGNEO INCAPSULATO IN ACCIAIO

woodcore high density conglomerato ligneo 600 x 600 mm

galvanized steel acciaio zincato 0.5 mm

covering: lay-loose tiles (carpet, pvc, rubber)

rivestimento superiore: moquette autoposante, gomma, pvc autoposante

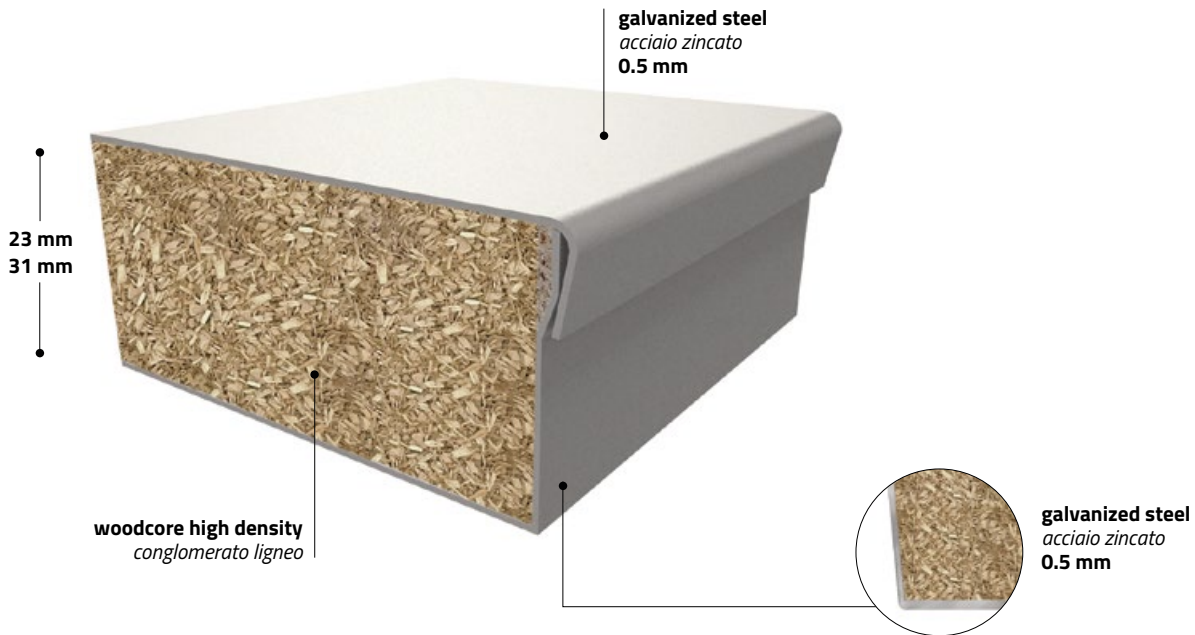

on request · a richiesta h 26 · 29 mm

TECHNICAL SPECIFICATIONS	CBL1 h 23 mm / kg 8,40	CBH h 31 mm / kg 10,30
fire reaction UNI EN 13501-1	Bfl-s1	
fire resistance UNI EN 13501-2	REI 30	
EPD® registration number	S-P-02179	

TECHNICAL FEATURES UNI EN 12825

CBI/ST	center of panel - deflection 2,5 mm	3,6 › 5,1 KN
	center of panel - ultimate load	9,5 › 15,7 KN
	loading class	4 › 6
CBI/CR	center of panel - deflection 2,5 mm	4,7 › 5,3 KN
	center of panel - ultimate load	12,0 › 16,4 KN
	loading class	6
IF tubular	center of panel - deflection 2,5 mm	4,9 › 5,6 KN
	center of panel - ultimate load	12,7 › 14,6 KN
	loading class	6

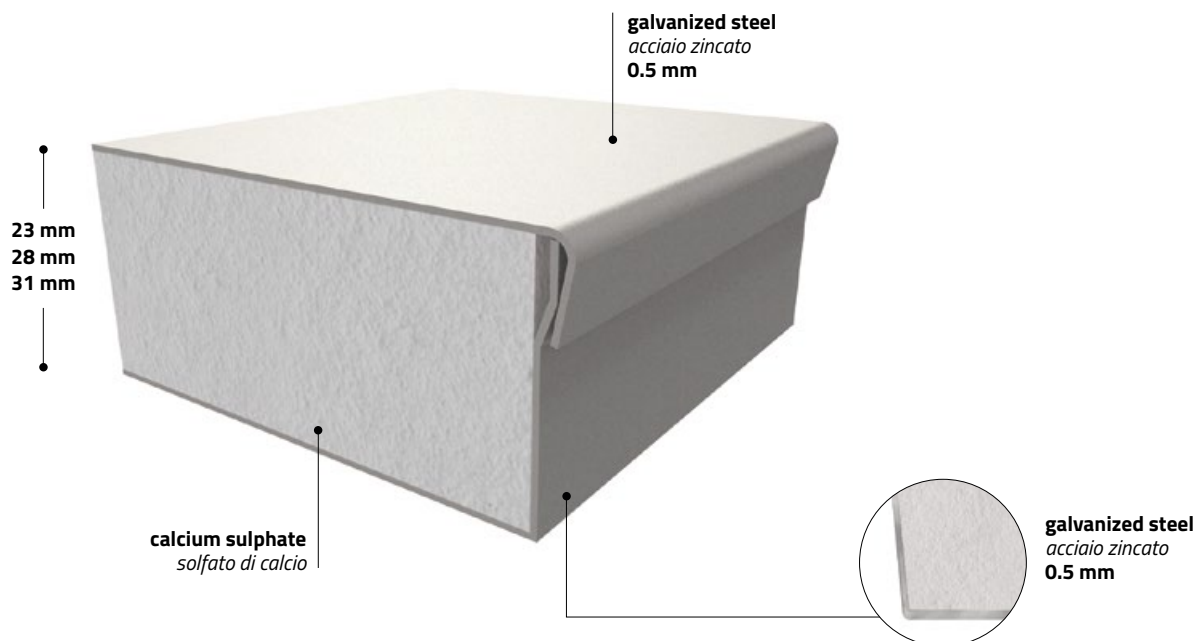

EN The load resistance tests have been performed in CBI Europe's internal laboratory and simulate the test method indicated by UNI EN 12825: 2001. The results obtained at a height of 20 cm may vary depending on the installation and the general conditions of the site. If the project requires a certification from a third party this must be explicitly requested. **IT** Le prove di resistenza al carico non sono state eseguite nel laboratorio interno CBI Europe e simulano il metodo di prova indicato dalla normativa UNI EN 12825:2001. I risultati ottenuti ad un'altezza di 20 cm possono variare in funzione dell'installazione e delle condizioni generali del cantiere. Qualora il progetto richieda una certificazione da un ente terzo questa dovrà essere espressamente richiesta.

BARE PANELS

CALCIUM SULPHATE PANELS › FULLY STEEL ENCAPSULATED*PANNELLO IN SOLFATO DI CALCIO INCAPSULATO IN ACCIAIO***calcium sulphate** *solfo di calcio* 600 x 600 mm**galvanized steel** *acciaio zincato* 0.5 mm**covering: lay-loose tiles (carpet, pvc, rubber)***rivestimento superiore: moquette autoposante, gomma, pvc autoposante*

TECHNICAL SPECIFICATIONS	CBL1/S h 23 mm / kg 12,50	CBM/S h 28 mm / kg 14,65	CBH/S h 31 mm / kg 15,50
fire reaction UNI EN 13501-1	A1		
fire resistance UNI EN 13501-2	> REI 60 <		
EPD® registration number	S-P-02180		

TECHNICAL FEATURES UNI EN 12825

CBI/ST	center of panel - deflection 2,5 mm	3,5 › 5,5 KN
	center of panel - ultimate load	10,6 › 14,5 KN
	loading class	5 › 6
CBI/CR	center of panel - deflection 2,5 mm	3,6 › 5,8 KN
	center of panel - ultimate load	11,2 › 15,2 KN
	loading class	5 › 6
IF tubular	center of panel - deflection 2,5 mm	3,9 › 6,1 KN
	center of panel - ultimate load	11,8 › 16,0 KN
	loading class	5 › 6

EN The load resistance tests have been performed in CBI Europe's internal laboratory and simulate the test method indicated by UNI EN 12825: 2001. The results obtained at a height of 20 cm may vary depending on the installation and the general conditions of the site. If the project requires a certification from a third party this must be explicitly requested. **IT** Le prove di resistenza al carico sono state eseguite nel laboratorio interno CBI Europe e simulano il metodo di prova indicato dalla normativa UNI EN 12825:2001. I risultati ottenuti ad un'altezza di 20 cm possono variare in funzione dell'installazione e delle condizioni generali del cantiere. Qualora il progetto richieda una certificazione da un ente terzo questa dovrà essere espressamente richiesta.

WOODCORE PANELS › FULLY STEEL ENCAPSULATED

PANNELLO IN CONGLOMERATO LIGNEO INCAPSULATO IN ACCIAIO

woodcore high density conglomerato ligneo 600 x 600 mm

galvanized steel acciaio zincato 0.5 mm

covering: lay-loose tiles (carpet, pvc, rubber)

rivestimento superiore: moquette autoposante, gomma, pvc autoposante



CORNER LOCK



23 mm
31 mm

galvanized steel
acciaio zincato
0.5 mm

woodcore high density
conglomerato ligneo

galvanized steel
acciaio zincato
0.5 mm

TECHNICAL SPECIFICATIONS		CBL1 h 23 mm / kg 8,40	CBH h 31 mm / kg 10,30
fire reaction UNI EN 13501-1		Bfl-s1	
fire resistance UNI EN 13501-2		REI 30	
EPD® registration number		S-P-02179	
TECHNICAL FEATURES UNI EN 12825			
	center of panel - deflection 2,5 mm	3,6 > 5,1 KN	
	center of panel - ultimate load	9,5 > 15,7 KN	
	loading class	4 > 6	

EN The load resistance tests have been performed in CBI Europe's internal laboratory and simulate the test method indicated by UNI EN 12825: 2001. The results obtained at a height of 20 cm may vary depending on the installation and the general conditions of the site. If the project requires a certification from a third party this must be explicitly requested. **IT** Le prove di resistenza al carico non sono state eseguite nel laboratorio interno CBI Europe e simulano il metodo di prova indicato dalla normativa UNI EN 12825:2001. I risultati ottenuti ad un'altezza di 20 cm possono variare in funzione dell'installazione e delle condizioni generali del cantiere. Qualora il progetto richieda una certificazione da un ente terzo questa dovrà essere espressamente richiesta.

BARE PANELS

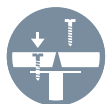
CALCIUM SULPHATE PANELS › FULLY STEEL ENCAPSULATED*PANNELLO IN SOLFATO DI CALCIO INCAPSULATO IN ACCIAIO***calcium sulphate** *solfo di calcio* **600 x 600 mm****galvanized steel** *acciaio zincato* **0.5 mm****covering: lay-loose tiles (carpet, pvc, rubber)***rivestimento superiore: moquette autoposante, gomma, pvc autoposante*

CORNER LOCK

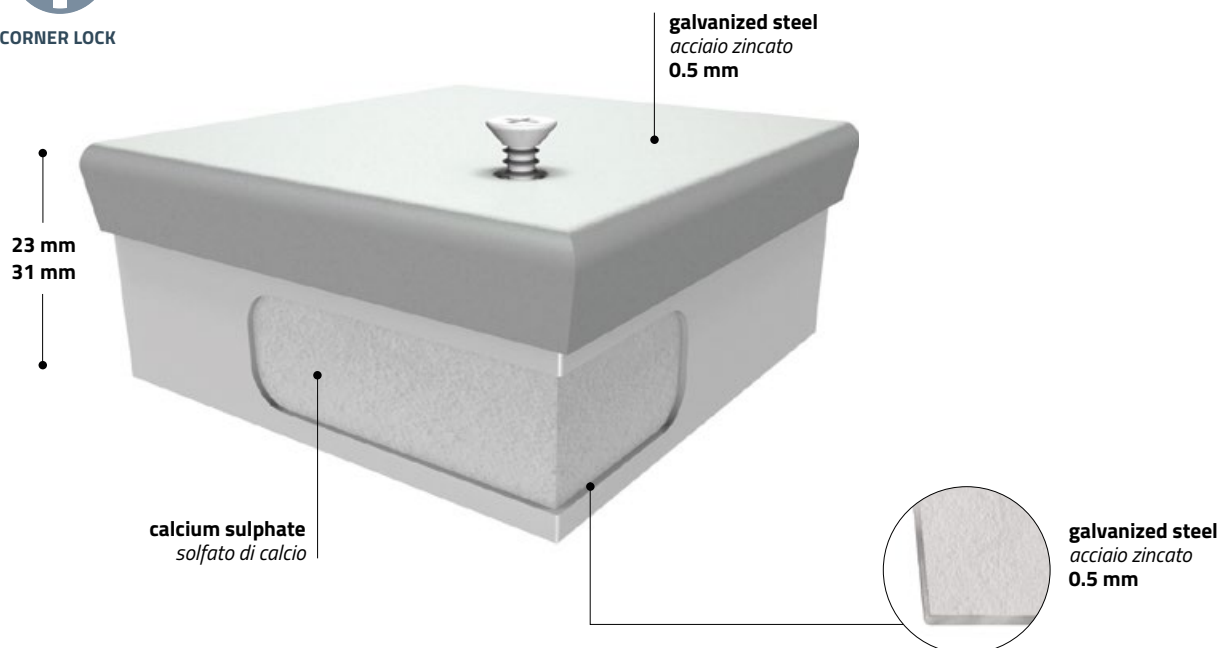

TECHNICAL SPECIFICATIONS		CBL1/S CORNER LOCK h 23 mm / kg 12,50	CBH/S CORNER LOCK h 31 mm / kg 15,50
fire reaction UNI EN 13501-1		Bfl-s1	
fire resistance UNI EN 13501-2		REI 30	
EPD® registration number		S-P-02180	
TECHNICAL FEATURES UNI EN 12825			
	center of panel - deflection 2,5 mm	3,5 > 5,5 KN	
	center of panel - ultimate load	10,6 > 14,5 KN	
	loading class	5 > 6	

EN The load resistance tests have been performed in CBI Europe's internal laboratory and simulate the test method indicated by UNI EN 12825: 2001. The results obtained at a height of 20 cm may vary depending on the installation and the general conditions of the site. If the project requires a certification from a third party this must be explicitly requested. **IT** Le prove di resistenza al carico sono state eseguite nel laboratorio interno CBI Europe e simulano il metodo di prova indicato dalla normativa UNI EN 12825:2001. I risultati ottenuti ad un'altezza di 20 cm possono variare in funzione dell'installazione e delle condizioni generali del cantiere. Qualora il progetto richieda una certificazione da un ente terzo questa dovrà essere espressamente richiesta.

WOODCORE PANELS › SEMI-ENCAPSULATED STEEL

PANNELLO IN CONGLOMERATO LIGNEO SEMI-INCAPSULATO IN ACCIAIO

woodcore high density conglomerato ligneo 600 x 600 mm

galvanized steel acciaio zincato 0.5 mm

covering: lay-loose tiles (carpet, pvc, rubber)

rivestimento superiore: moquette autoposante, gomma, pvc autoposante



TECHNICAL SPECIFICATIONS	CBI28T h 28,5 mm / kg 8,45	CBI30T h 30,5 mm / kg 9.30
fire reaction UNI EN 13501-1	Bfl-s1	
fire resistance UNI EN 13501-2	REI 30	
EPD® registration number	S-P-02179	

TECHNICAL FEATURES UNI EN 12825		
CBI/ST	center of panel - deflection 2,5 mm	3,3 > 3,5 KN
	center of panel - ultimate load	9,8 > 10,3 KN
	loading class	4
CBI/CR	center of panel - deflection 2,5 mm	3,5 > 3,7 KN
	center of panel - ultimate load	10,3 > 10,8 KN
	loading class	5
IF tubular	center of panel - deflection 2,5 mm	3,6 > 3,8 KN
	center of panel - ultimate load	10,8 > 11,3 KN
	loading class	5

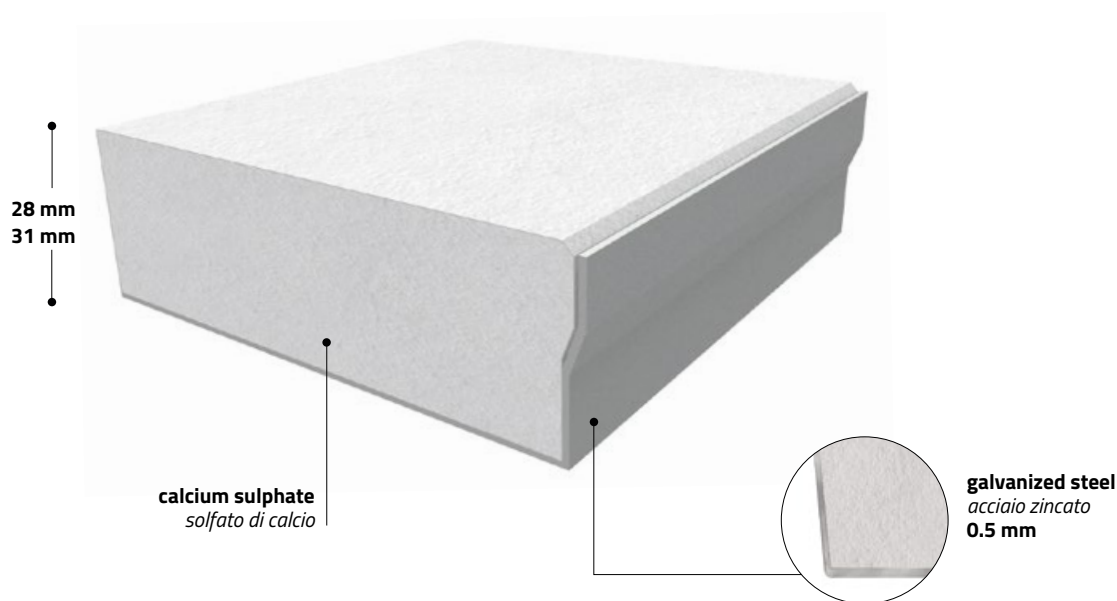

EN The load resistance tests have been performed in CBI Europe's internal laboratory and simulate the test method indicated by UNI EN 12825: 2001. The results obtained at a height of 20 cm may vary depending on the installation and the general conditions of the site. If the project requires a certification from a third party this must be explicitly requested. **IT** Le prove di resistenza al carico non sono state eseguite nel laboratorio interno CBI Europe e simulano il metodo di prova indicato dalla normativa UNI EN 12825:2001. I risultati ottenuti ad un'altezza di 20 cm possono variare in funzione dell'installazione e delle condizioni generali del cantiere. Qualora il progetto richieda una certificazione da un ente terzo questa dovrà essere espressamente richiesta.

BARE PANELS

CALCIUM SULPHATE PANELS › SEMI-ENCAPSULATED STEEL*PANNELLO IN SOLFATO DI CALCIO SEMI-INCAPSULATO IN ACCIAIO***calcium sulphate** *solfo di calcio* **600 x 600 mm****galvanized steel** *acciaio zincato* **0.5 mm****covering: lay-loose tiles (carpet, pvc, rubber)***rivestimento superiore: moquette autoposante, gomma, pvc autoposante*

TECHNICAL SPECIFICATIONS	CBI28S h 28 mm / kg 13,25	CBI31S h 31 mm / kg 14,50
fire reaction UNI EN 13501-1	A1	
fire resistance UNI EN 13501-2	> REI 60 <	
EPD® registration number	S-P-02180	

TECHNICAL FEATURES UNI EN 12825

	center of panel - deflection 2,5 mm	3,4 > 4KN
	center of panel - ultimate load	8,6 > 8,8 KN
	loading class	3
	center of panel - deflection 2,5 mm	4,2 > 4,6 KN
	center of panel - ultimate load	9,6 > 10,2 KN
	loading class	4 > 5
	center of panel - deflection 2,5 mm	4,7 > 4,9 KN
	center of panel - ultimate load	9,9 > 10,5 KN
	loading class	4 > 5

EN The load resistance tests have been performed in CBI Europe's internal laboratory and simulate the test method indicated by UNI EN 12825: 2001. The results obtained at a height of 20 cm may vary depending on the installation and the general conditions of the site. If the project requires a certification from a third party this must be explicitly requested. **IT** Le prove di resistenza al carico sono state eseguite nel laboratorio interno CBI Europe e simulano il metodo di prova indicato dalla normativa UNI EN 12825:2001. I risultati ottenuti ad un'altezza di 20 cm possono variare in funzione dell'installazione e delle condizioni generali del cantiere. Qualora il progetto richieda una certificazione da un ente terzo questa dovrà essere espressamente richiesta.

HYBRID PANELS › FULLY STEEL ENCAPSULATED



PANNELLO HYBRID INCAPSULATO IN ACCIAIO

woodcore high density + calcium sulphate conglomerato ligneo + solfato di calcio **600 x 600 mm**
galvanized steel acciaio zincato **0.5 mm**

covering: lay-loose tiles (carpet, pvc, rubber)

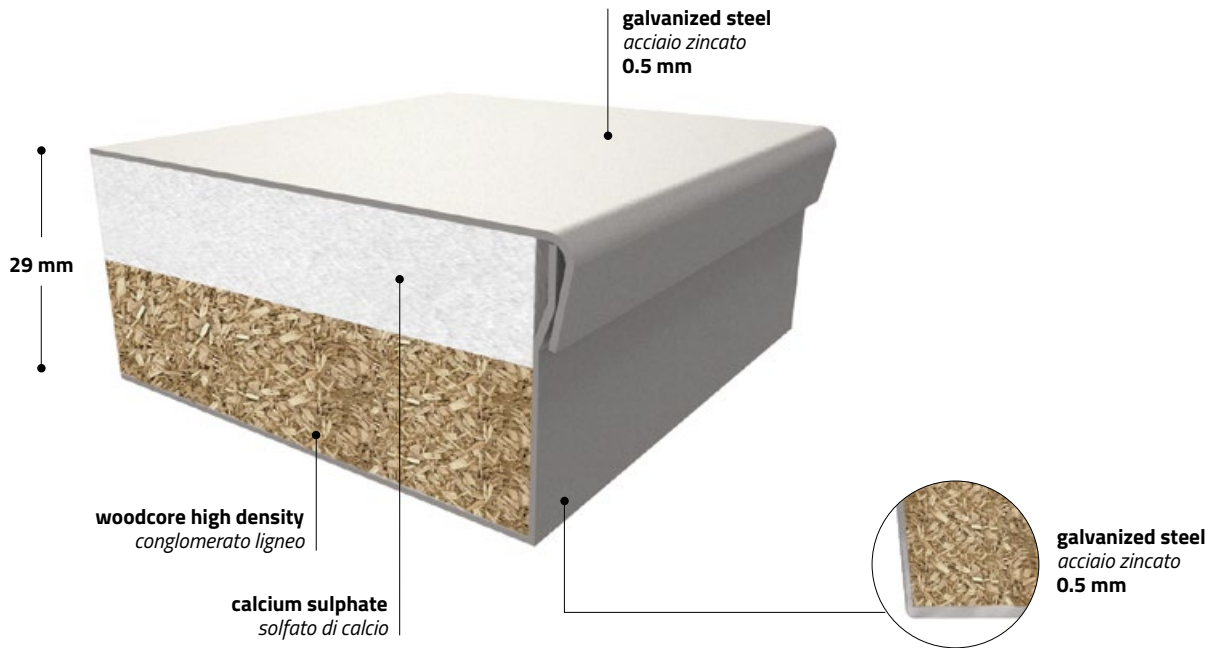
rivestimento superiore: moquette autoposante, gomma, pvc autoposante



TECHNICAL SPECIFICATIONS		CBI30-HYBRID h 29 mm / kg 12,30
fire reaction UNI EN 13501-1		A1
fire resistance UNI EN 13501-2		> REI 60 <
TECHNICAL FEATURES UNI EN 12825		
CBI/ST 	center of panel - deflection 2,5 mm	4,0 KN
	center of panel - ultimate load	10,3 KN
	loading class	5
CBI/CR 	center of panel - deflection 2,5 mm	4,2 KN
	center of panel - ultimate load	10,8 KN
	loading class	5

EN The load resistance tests have been performed in CBI Europe's internal laboratory and simulate the test method indicated by UNI EN 12825: 2001. The results obtained at a height of 20 cm may vary depending on the installation and the general conditions of the site. If the project requires a certification from a third party this must be explicitly requested. **IT** Le prove di resistenza al carico non sono state eseguite nel laboratorio interno CBI Europe e simulano il metodo di prova indicato dalla normativa UNI EN 12825:2001. I risultati ottenuti ad un'altezza di 20 cm possono variare in funzione dell'installazione e delle condizioni generali del cantiere. Qualora il progetto richieda una certificazione da un ente terzo questa dovrà essere espressamente richiesta.

BARE PANELS



HYBRID PANELS > SEMI-ENCAPSULATED STEEL**PANNELLO HYBRID SEMI-INCAPSULATO IN ACCIAIO**

woodcore high density + calcium sulphate *conglomerato ligneo + solfato di calcio* **600 x 600 mm**
galvanized steel *acciaio zincato* **0.5 mm**

covering: lay-loose tiles (carpet, pvc, rubber)

rivestimento superiore: moquette autoposante, gomma, pvc autoposante



TECHNICAL SPECIFICATIONS		CB128-HYBRID h 28 mm / kg 11,10
fire reaction UNI EN 13501-1		A1
fire resistance UNI EN 13501-2		> REI 60 <
TECHNICAL FEATURES UNI EN 12825		
 CBI/ST	center of panel - deflection 2,5 mm	3,9 KN
	center of panel - ultimate load	10,0 KN
	loading class	5
 CBI/CR	center of panel - deflection 2,5 mm	4,1 KN
	center of panel - ultimate load	10,5 KN
	loading class	5

EN The load resistance tests have been performed in CBI Europe's internal laboratory and simulate the test method indicated by UNI EN 12825: 2001. The results obtained at a height of 20 cm may vary depending on the installation and the general conditions of the site. If the project requires a certification from a third party this must be explicitly requested. **IT** Le prove di resistenza al carico sono state eseguite nel laboratorio interno CBI Europe e simulano il metodo di prova indicato dalla normativa UNI EN 12825:2001. I risultati ottenuti ad un'altezza di 20 cm possono variare in funzione dell'installazione e delle condizioni generali del cantiere. Qualora il progetto richieda una certificazione da un ente terzo questa dovrà essere espressamente richiesta.

FLOOR SYSTEM **CBI/ST** without stringers

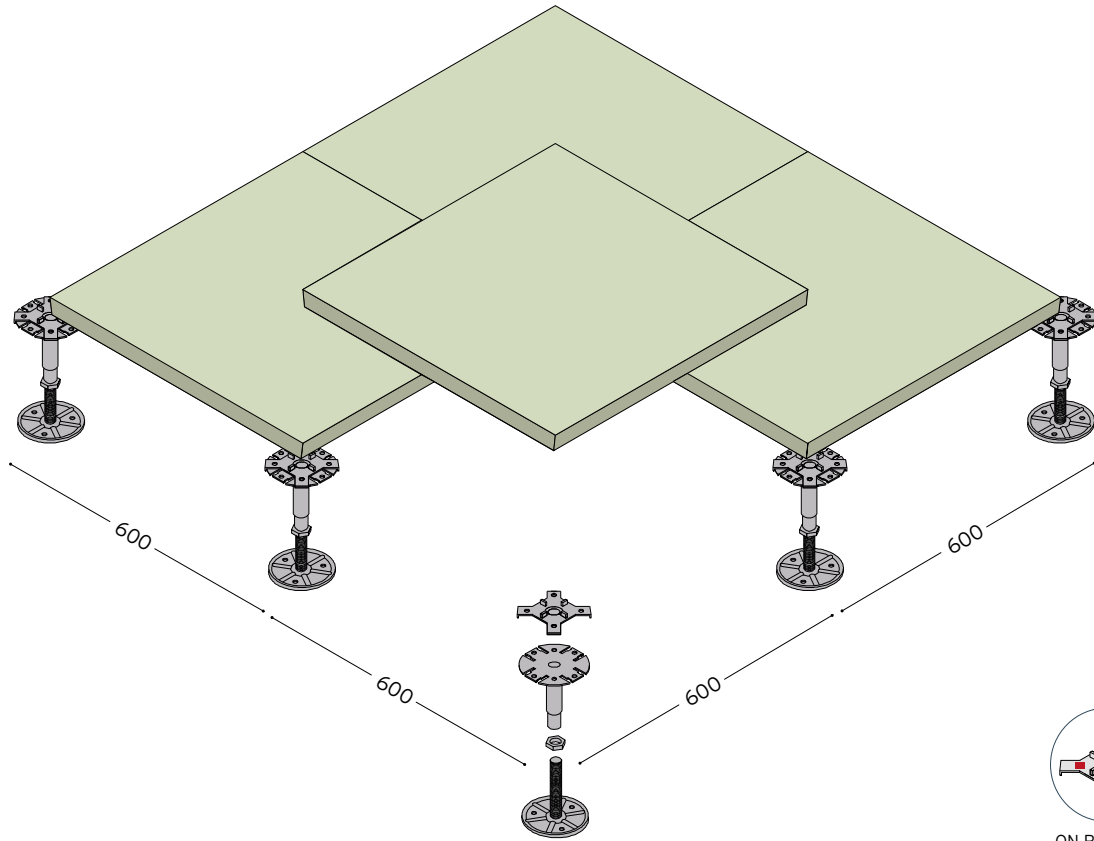

ON REQUEST
conductive washer
 guarnizione conduttiva
HGT 300/C.1

adjustable pedestal piedino regolabile

CBI F12

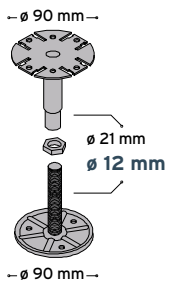

code codice	height/mm altezza/mm	weight/pcs peso/pcs
CBIO3F12	45/65	0,23 Kg
CBIO4F12	61/90	0,24 Kg
CBIO5F12	83/130	0,27 Kg
CBIO6F12	120/200	0,30 Kg

CBI F16

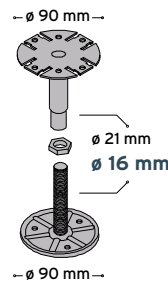

code codice	height/mm altezza/mm	weight/pcs peso/pcs
CBIO3F16	45/65	0,30 Kg
CBIO4F16	61/90	0,34 Kg
CBIO5F16	83/130	0,39 Kg
CBIO6F16	120/200	0,45 Kg
CBIO7F16	170/290	0,55 Kg

FLOOR SYSTEM **CBI** with stringers

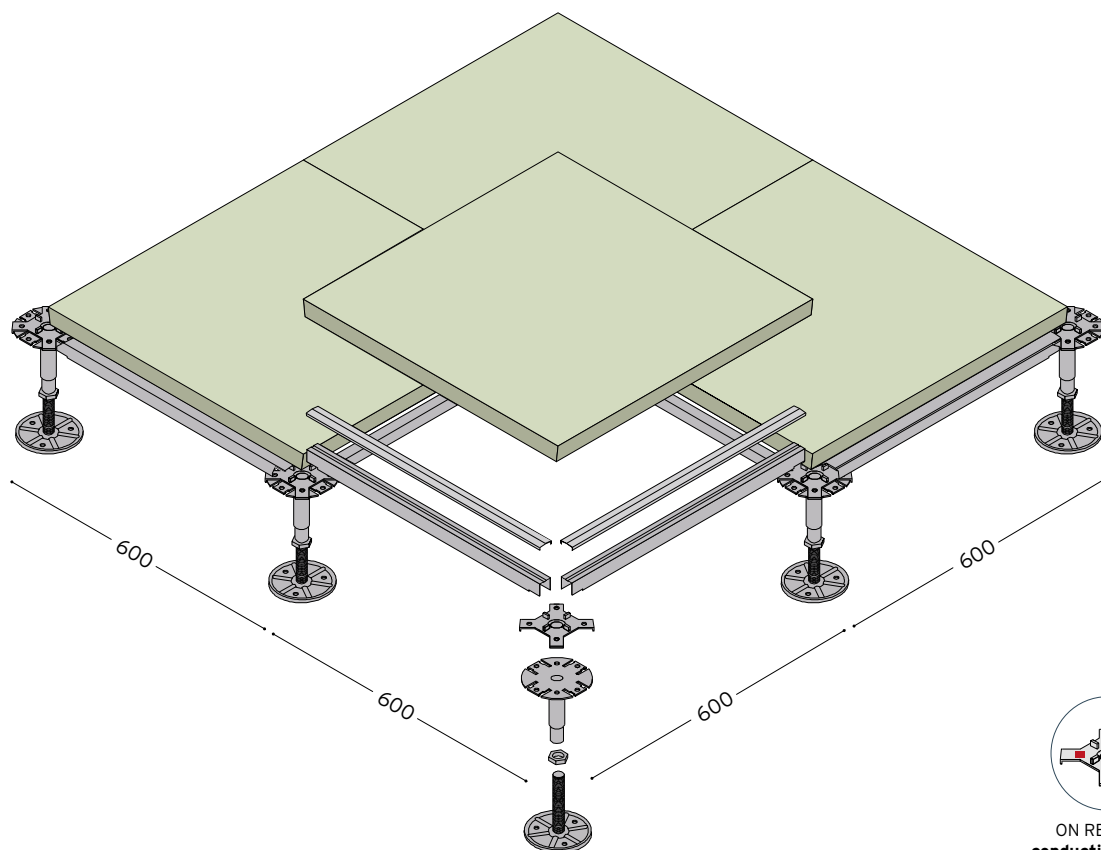

ON REQUEST
conductive washer
guarnizione conduttiva
HGT 300/C.1

adjustable pedestal piedino regolabile

CBI F12

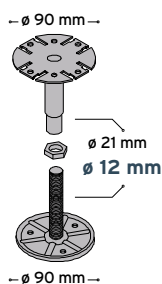

code codice	height/mm altezza/mm	weight/pcs peso/pcs
CBIO3F12	45/65	0,23 Kg
CBIO4F12	61/90	0,24 Kg
CBIO5F12	83/130	0,27 Kg
CBIO6F12	120/200	0,30 Kg

CBI F16

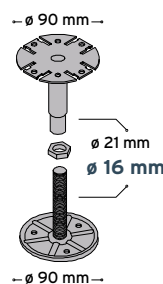

code codice	height/mm altezza/mm	weight/pcs peso/pcs
CBIO3F16	45/65	0,30 Kg
CBIO4F16	61/90	0,34 Kg
CBIO5F16	83/130	0,39 Kg
CBIO6F16	120/200	0,45 Kg
CBIO7F16	170/290	0,55 Kg
CBIO8F16	250/390	0,70 Kg
CBIO9F16	350/490	0,83 Kg
CBIO10F16	450/650	1,00 Kg

stringers traversa

T536/A HEAVY

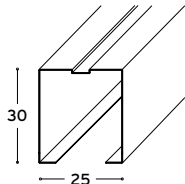

T536/L LIGHT

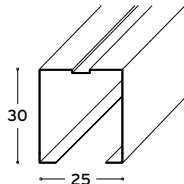

T536/S SPACER

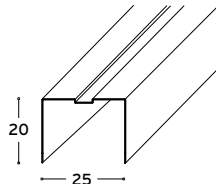

open section stringer made with galvanised steel,
Clip-On System with PVC washer.
traversa di collegamento a sezione aperta in acciaio zincato
mod. Clip-On con guarnizioni di tenuta.

T536/A 30 x 25 · thk sp.1 mm
T536/L 30 x 25 · thk sp.0,7 mm
T536/S 20 x 25 · thk sp.0,7 mm

FLOOR SYSTEM CR

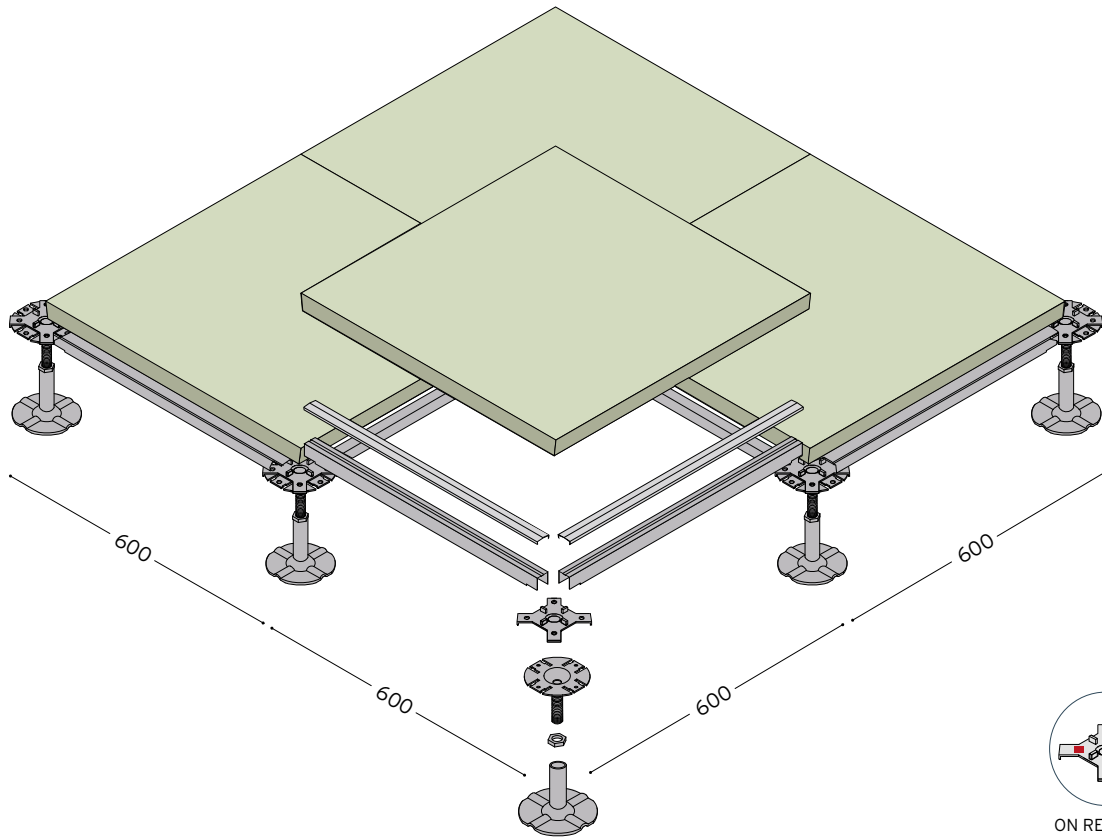

ON REQUEST
conductive washer
 guarnizione conduttiva
HGT 300/C.1

adjustable pedestal piedino regolabile

CR

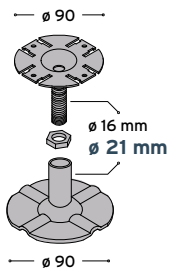

code codice	height/mm altezza/mm	weight/pcs peso/pcs
CRO0F16	120/200	0,55 Kg
CRO1F16	200/350	0,68 Kg
CRO2F16	350/550	0,94 Kg
CRO3F18	550/800	1,34 Kg
CRO4F20	800/1050	1,85 Kg
CRO5F20	1050/1300	2,14 Kg

stringers traversa

T536/A
HEAVY

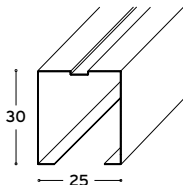

T536/L
LIGHT

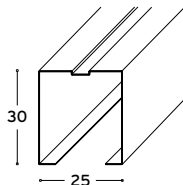

open section stringer made with galvanised steel, Clip-On / Screw Down System with PVC washer.
 traversa di collegamento a sezione aperta in acciaio zincato mod. Clip-On / Screw Down con guarnizioni di tenuta.

T536/A 30 x 25 · thk sp. 1 mm
T536/L 30 x 25 · thk sp. 0,7 mm

FLOOR SYSTEM **CBI/CR**

high load-bearing capacity dedicated to data centres, technical rooms, laboratories

alta resistenza al carico dedicata a data center, locali tecnici, laboratori

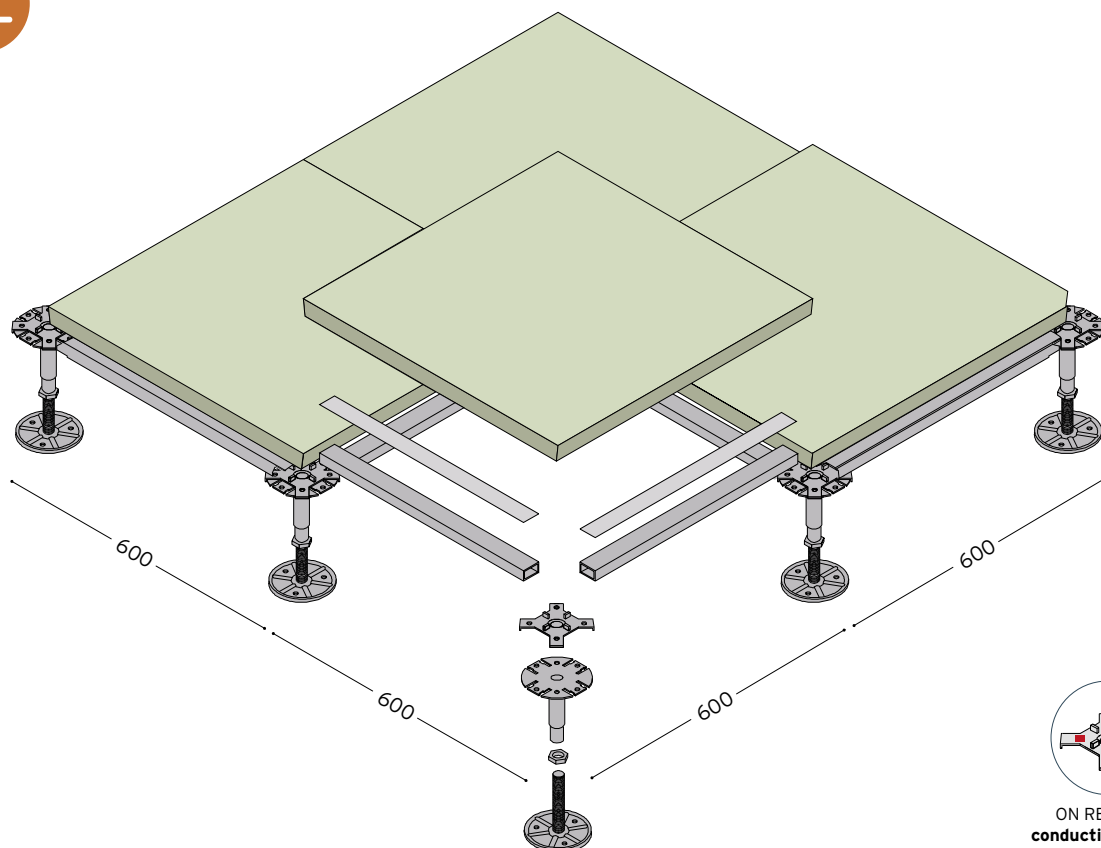

ON REQUEST
conductive washer
guarnizione conduttiva
HGT 300/C.1

adjustable pedestal piedino regolabile

CR

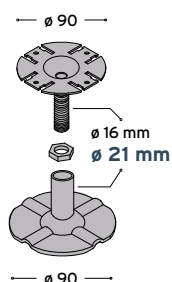

code codice	height/mm altezza/mm	weight/pcs peso/pcs
CR00F16	120/200	0,55 Kg
CR01F16	200/350	0,68 Kg
CR02F16	350/550	0,94 Kg
CR03F18	550/800	1,34 Kg
CR04F20	800/1050	1,85 Kg
CR05F20	1050/1300	2,14 Kg

CBI F16

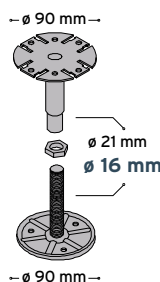

code codice	height/mm altezza/mm	weight/pcs peso/pcs
CB103F16	45/65	0,30 Kg
CB104F16	61/90	0,34 Kg
CB105F16	83/130	0,39 Kg
CB106F16	120/200	0,45 Kg
CB107F16	170/290	0,55 Kg
CB108F16	250/390	0,70 Kg
CB109F16	350/490	0,83 Kg
CB110F16	450/650	1,00 Kg

stringers traversa

TT545

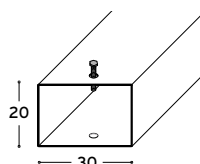

tubular stringers closed section 30x20x1 mm Screws Down System, including screws for fixing on top of pedestals including washer.
traversa tubolare sezione chiusa 30x20x1 mm sistema Screw Down, comprensiva di viti per il fissaggio sulla testa del piedino e guarnizione.

TT545 20 x 30 · thk sp. 1 mm

METEOR ceramic tiles *gres porcellanato*

available sizes *formato disponibile* 600 x 600 x 10,5 mm

available finishing: unpolished / polished *finiture disponibili: naturale / levigata*

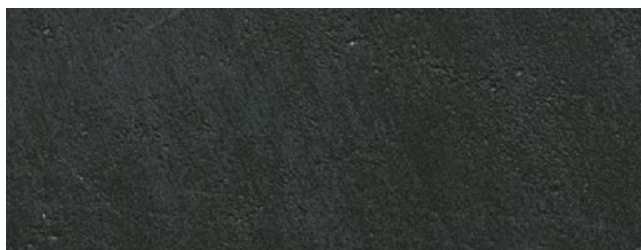

grafite

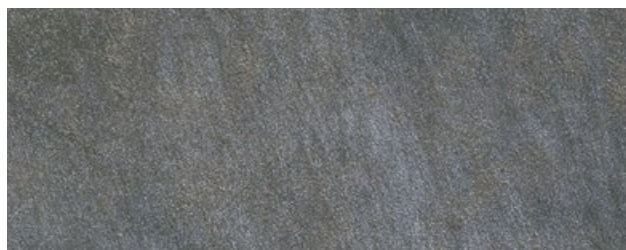

nero



india green



grigio



brown



blu

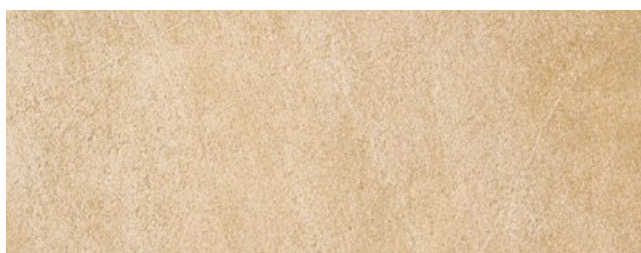

beige

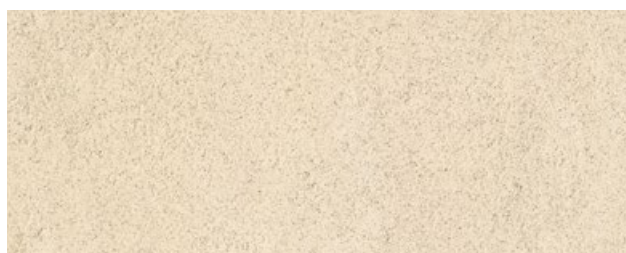

almond



perla

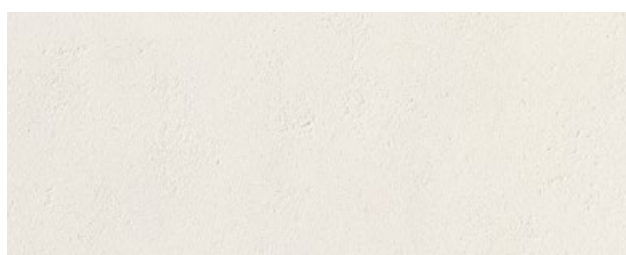

bianco

WALK ceramic tiles *gres porcellanato*

available sizes *formato disponibile* **600 x 600 x 10,5 mm**

available finishing: **unpolished** *finiture disponibili: naturale*



60DG



60TO



60G

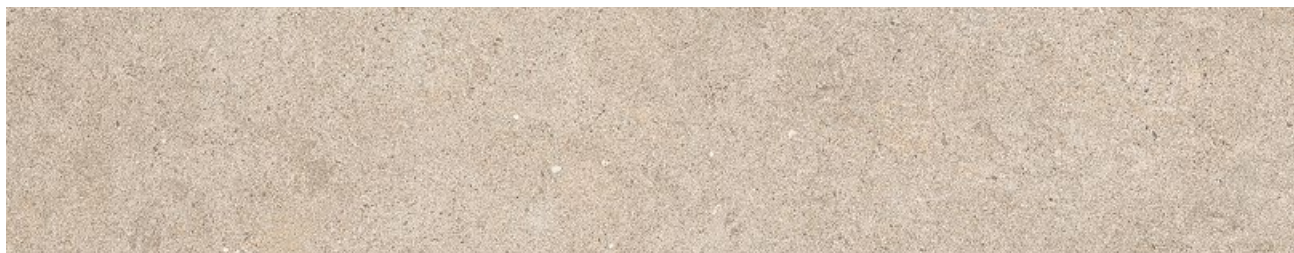

60B

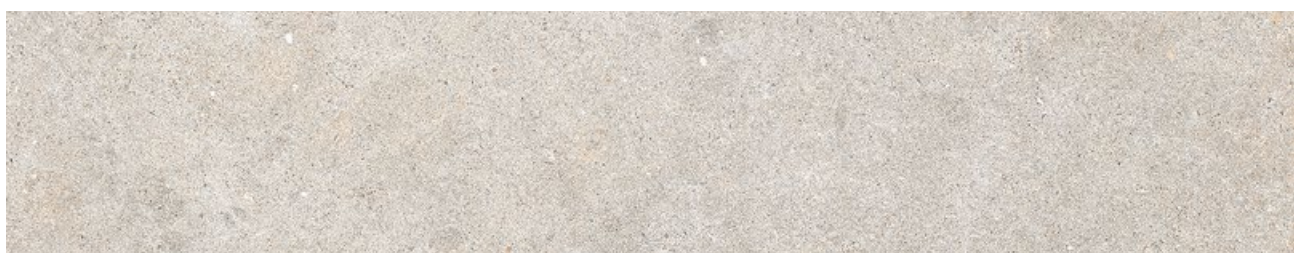

60W

ARCHITECTURE ceramic tiles *gres porcellanato*

available sizes *formato disponibile* **600 x 600 x 10,5 mm**

available finishing: **unpolished** *finiture disponibili: naturale*

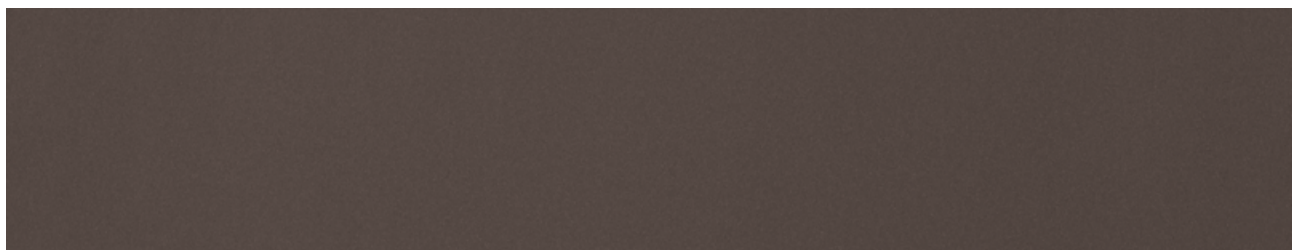

dark brown matt

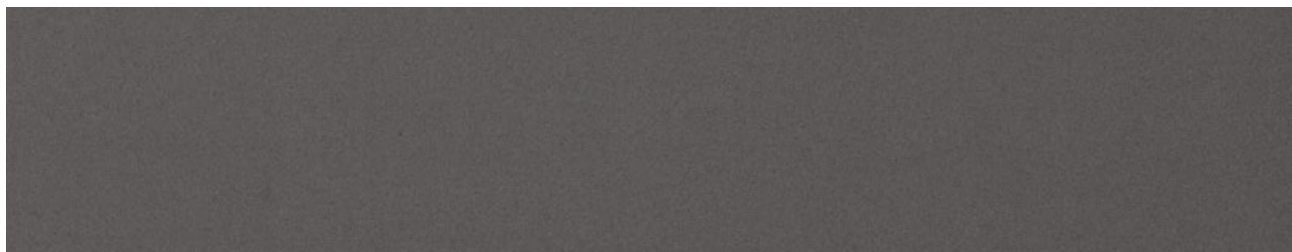

dark grey matt

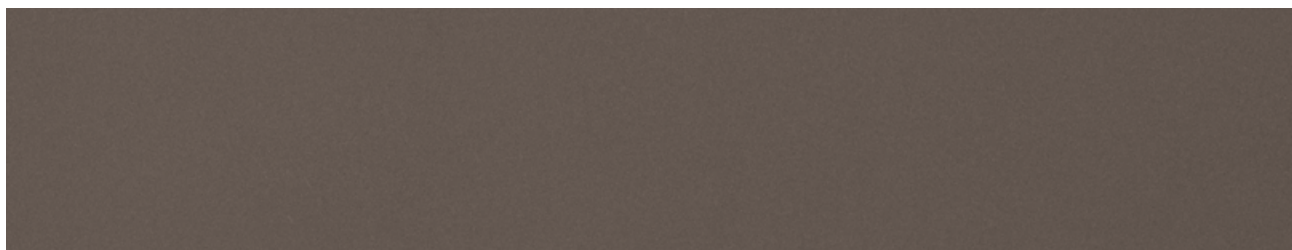

light brown matt

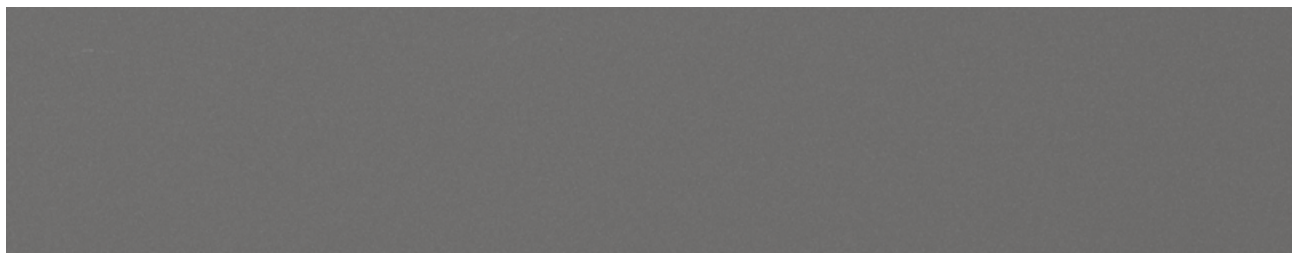

medium grey matt

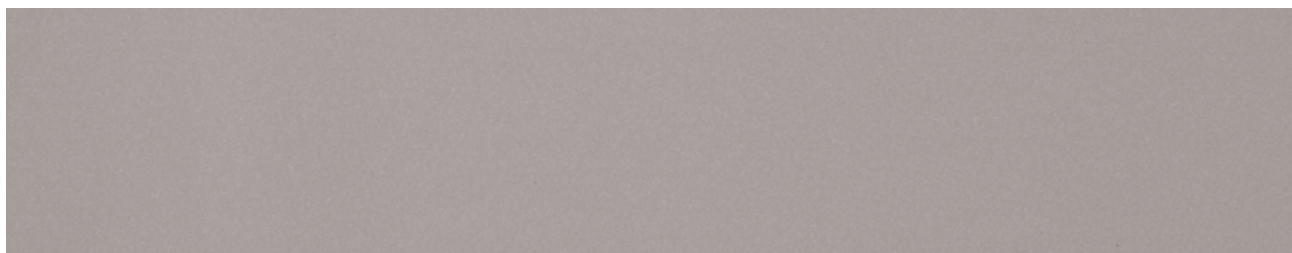

light grey matt

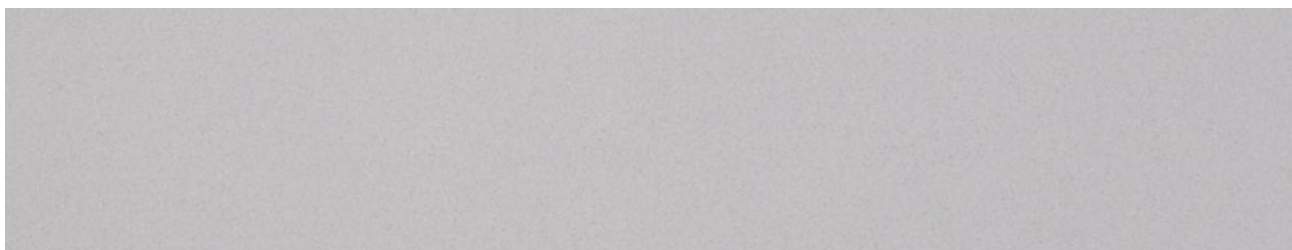

cool grey matt

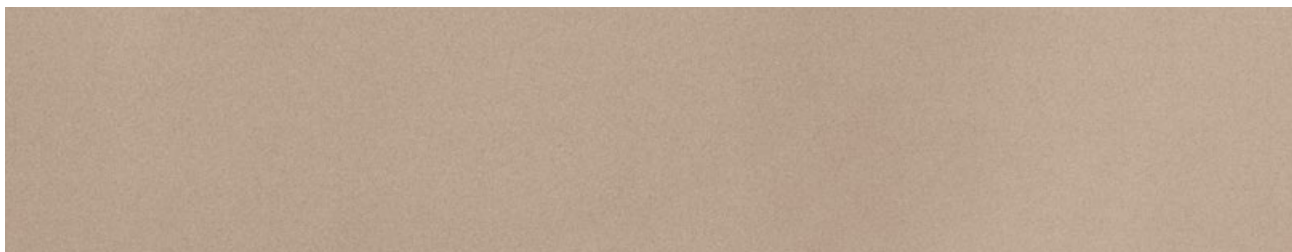

beige matt

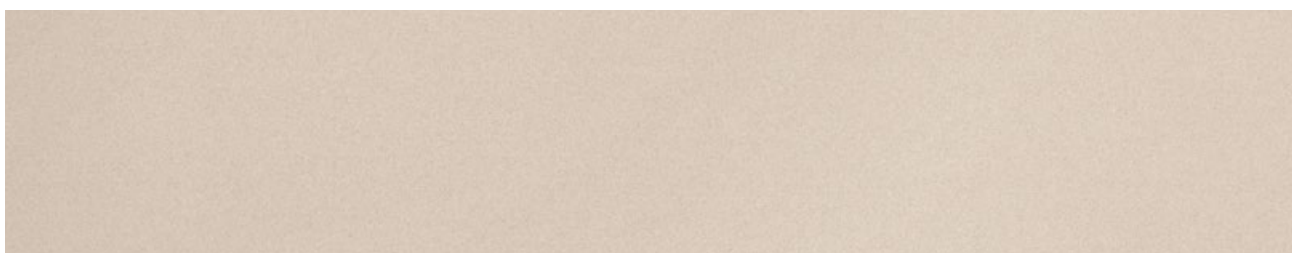

dark ivory matt

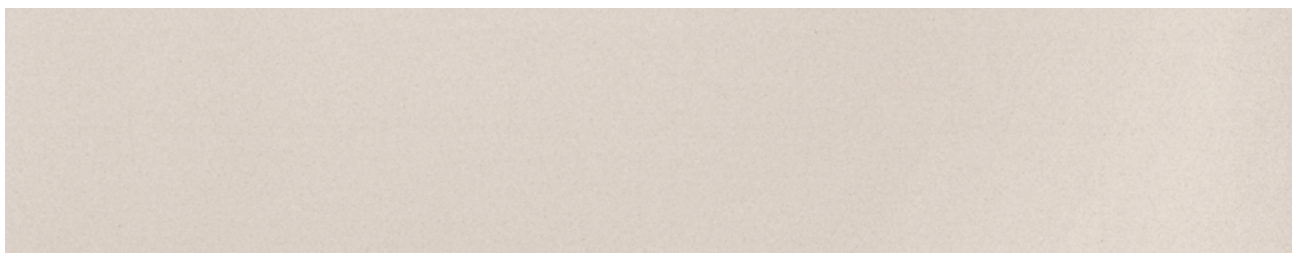

warm grey matt

MARMOKER ceramic tiles marble imitation gres porcellanato effetto marmorizzato

available sizes *formato disponibile* 600 x 600 x 10,5 mm

available finishing: **polished** *finiture disponibili: levigata*

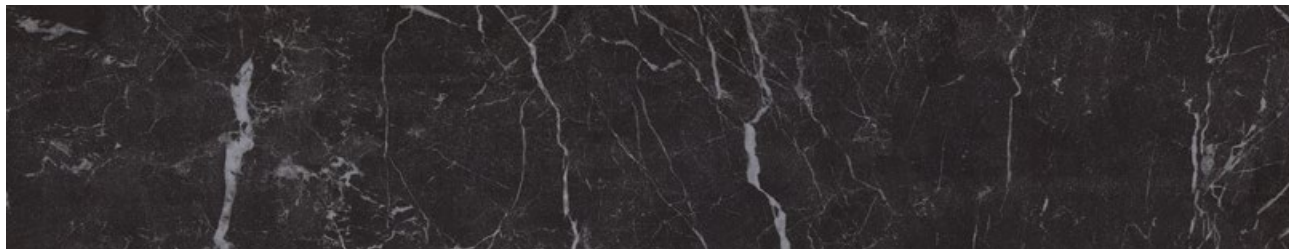

nero creta



breccia carsica

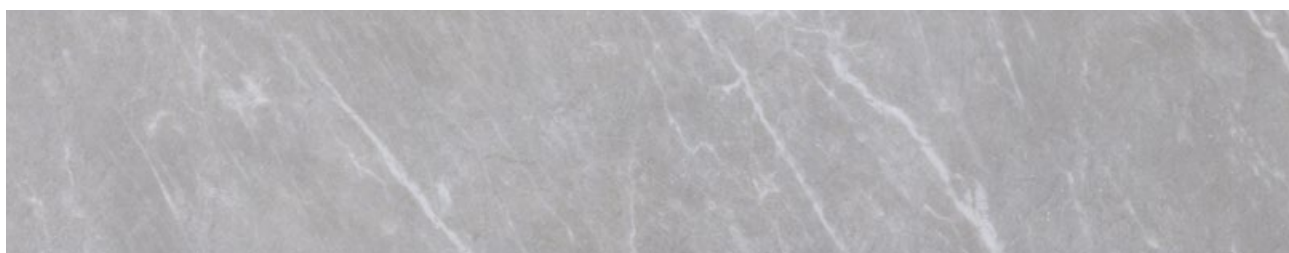

bardiglio imperiale



pulpis tortora

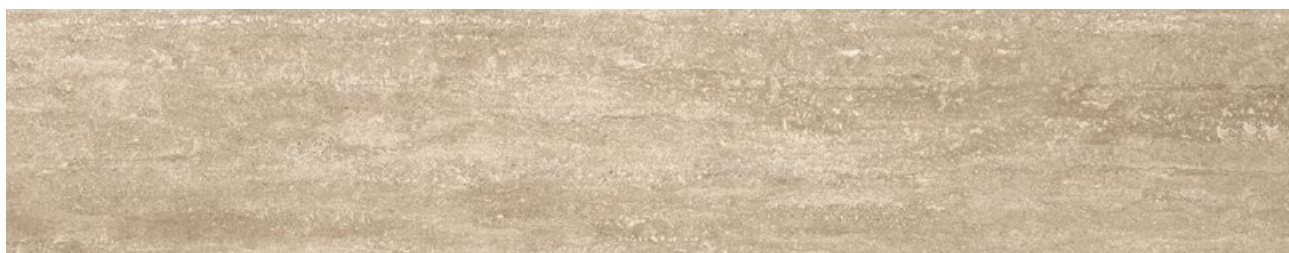

travertino romano

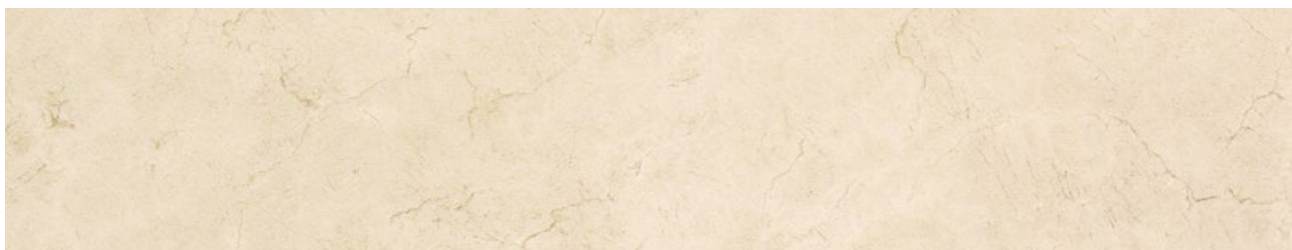

crema select



travertino bianco



statuario oro



statuario grigio

SOLID WOOD PARQUET essences *essenze*

available sizes *formato disponibile* **600 x 600**

standard thickness *spessore standard* **4 mm** · **other thickness on request** *altri spessori a richiesta*

 **SOFT COVERINGS**

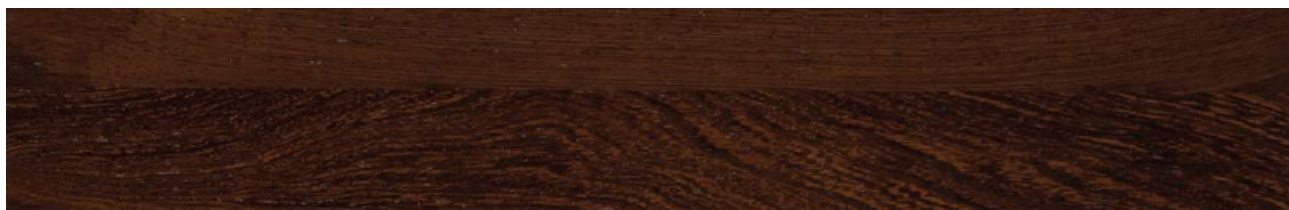

wengé · *wengé*



teak · *teak*



doussié africa · *africa doussié*

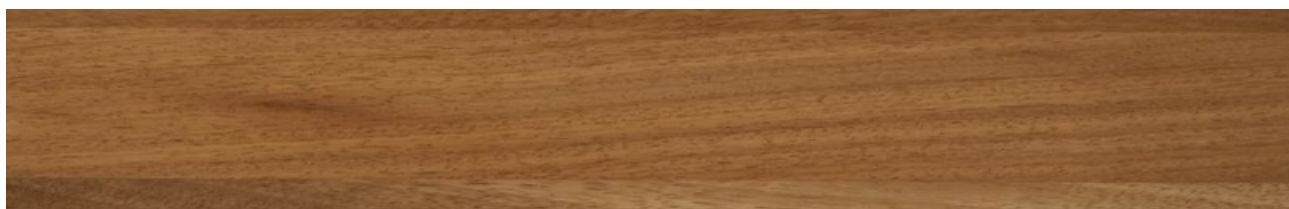

iroko · *iroko*

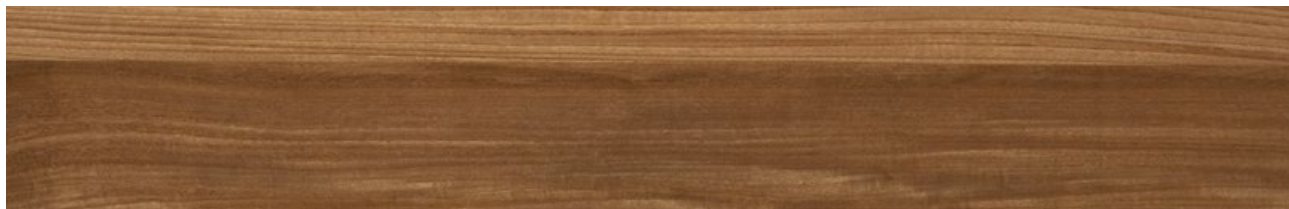

afromosia · *afromosia*



europe cherry · *ciliegio europa*



beech · *faggio*

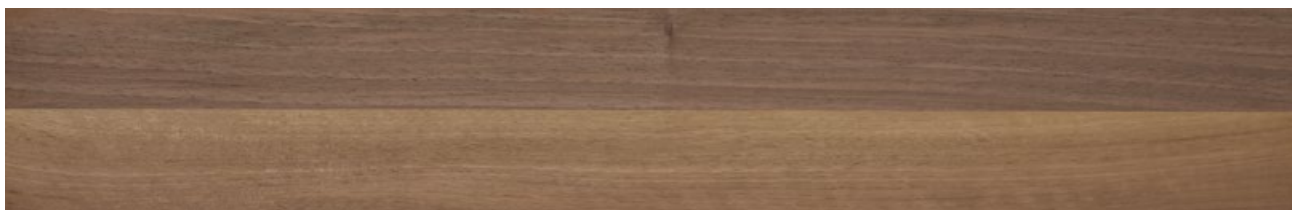

europa walnut · *noce europa*



oak · *rovere*



ash · *frassino*

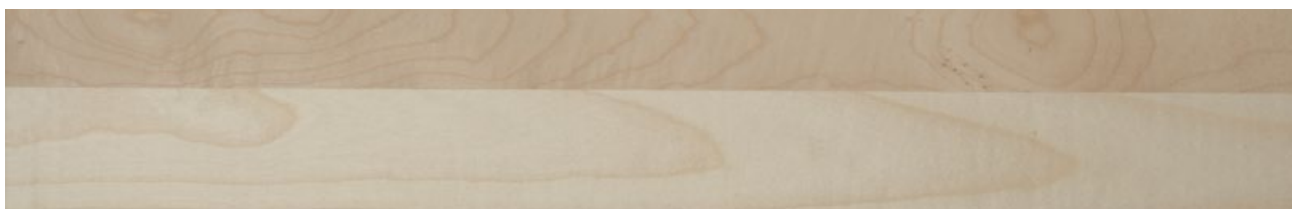

europa maple · *acero europa*

PARQUET DESIGN

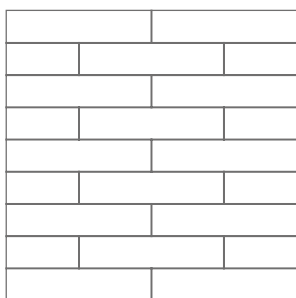

quarterdeck · *cassero*

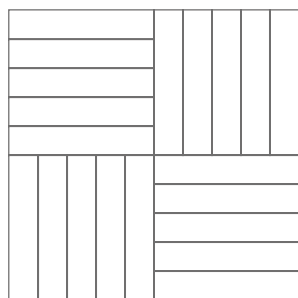

mosaic · *mosaico*

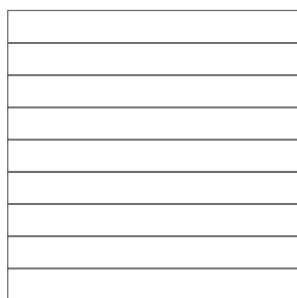

main deck · *tolda di nave*

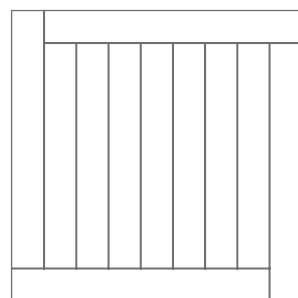

friuli · *friuli*

Other types of solid wood parquet available on request *Altri tipi di parquet disponibili a richiesta*

SOLID WOOD BAMBOO bamboo bambú

available sizes *formato disponibile* **600 x 600**

standard thickness *spessore standard* **5 mm**



oak bamboo · *rovere bamboo*



ash bamboo · *frassino bamboo*

Strong, environment-friendly, and extremely stable.

The addition of a bamboo finish to CBI Europe's raised access floor range offers a greener, alternative floor surface. The introduction of bamboo is tangible proof of CBI Europe's commitment to protecting the environment.

Bamboo is not only extremely strong but is the world's fastest growing plant (it can grow up to a metre a day in tropical regions). Use of bamboo therefore makes a major contribution to reducing the problem of deforestation. Often referred to as "natural steel", bamboo is cool to the touch in the summer and warm in the winter.

Resistente, ecocompatibile ed altamente stabile.

L'inserimento della finitura in bambu all'interno della gamma Raised Access Floors rappresenta la scelta verde ed alternativa di CBI, frutto di un concreto impegno a vantaggio dell'ambiente: il bambu non è solamente una pianta molto resistente, ma è anche quella con la crescita più rapida al mondo - oltre un metro al giorno nelle regioni tropicali - fattore che riduce di fatto il problema delle deforestazioni.

Denominato anche "acciaio naturale", risulta al tatto fresco d'estate e caldo d'inverno.

LINOLEUM

available sizes *formato disponibile* 600 x 600 mm

thickness *spessore* 2,0 / 2,5 / 3,2 mm

 SOFT COVERINGS



672 aluminum



911 burlap



679 cork



711 ecru



703 fog



906 graphite



793 grey



633 horizon



604 pebble



625 silk



611 sisal



608 smoke



673 steel



702 storm

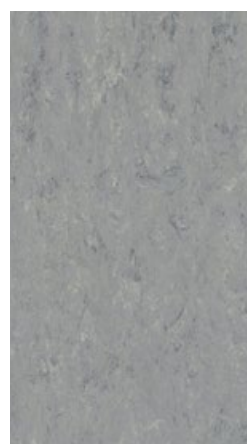

671 zinc

The linoleum tiles used from CBI Europe are all original Tarkett *I linoleum utilizzati da CBI Europe sono tutti originali Tarkett*
Other types of linoleum, available on request *Altri tipi di linoleum disponibili a richiesta*

ANTISTATIC HPL - STANDARD

available sizes *formato disponibile* 600 x 600 mm

thickness *spessore* 0,9 mm · other thickness on request *altri spessori a richiesta*

 SOFT COVERINGS



577 grey · *grigio*

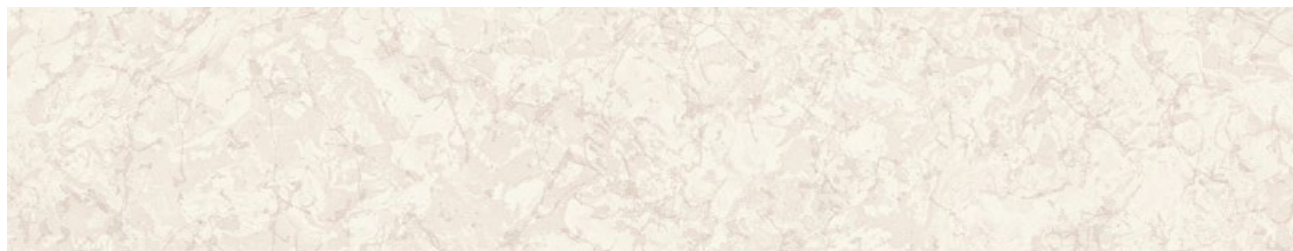

576 ivory · *avorio*



546 rocks · *tivoli*

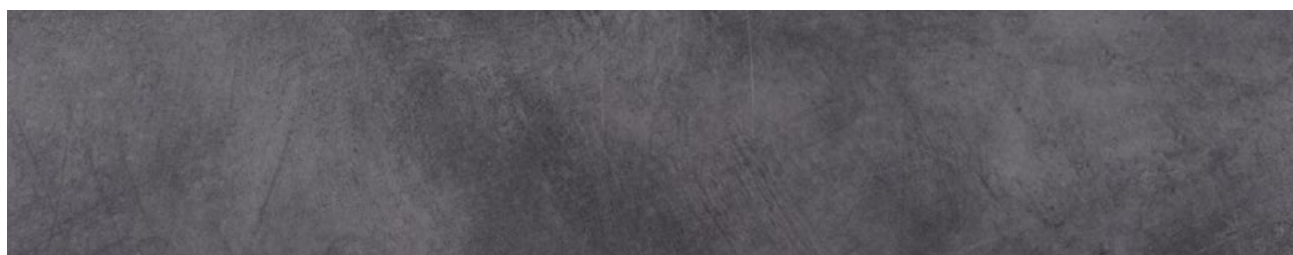

2810 cement · *cemento*



548 rocks · *piasentina*

Other types of antistatic HPL available on request *Altri tipi di laminato antistatico disponibili a richiesta.* · **The standard coverings used are all original Abet Walkprint finishing type SEI.** *I rivestimenti standard utilizzati sono tutti originali Abet Walkprint finitura SEI.*

[continue · segue >](#)

CBI Europe exclusive finish
finitura esclusiva CBI Europe

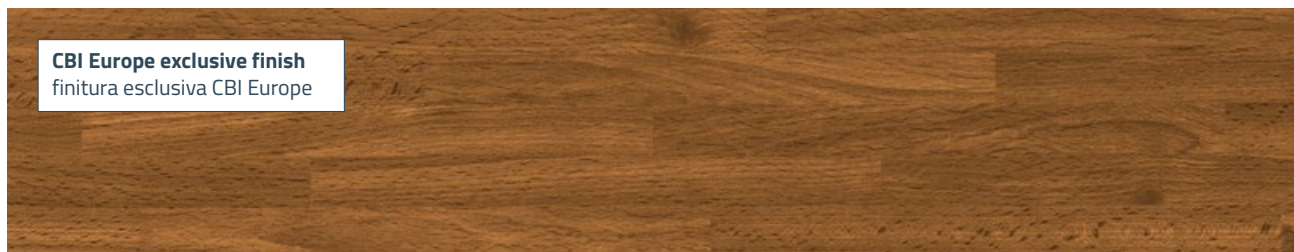

9792 planked walnut · *noce listellare*

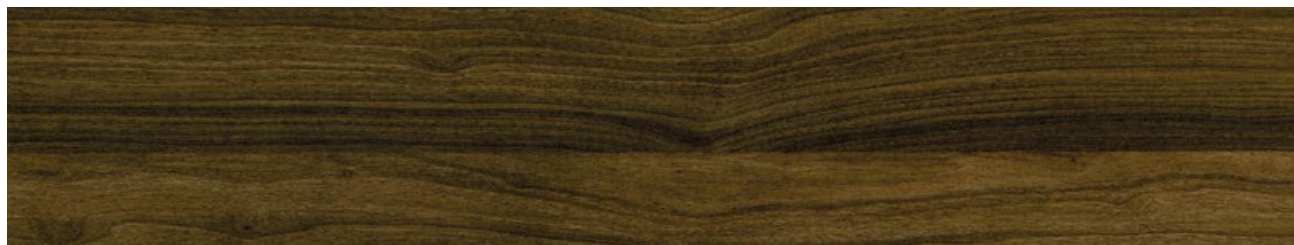

616 walnut sabec · *noce sabec*

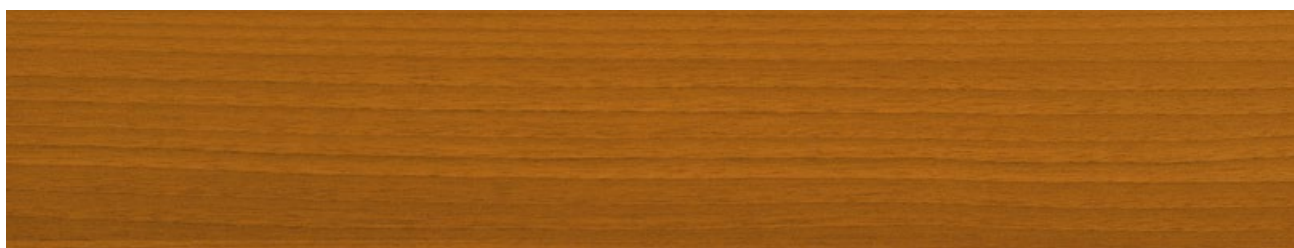

1329 doussié · *doussié*

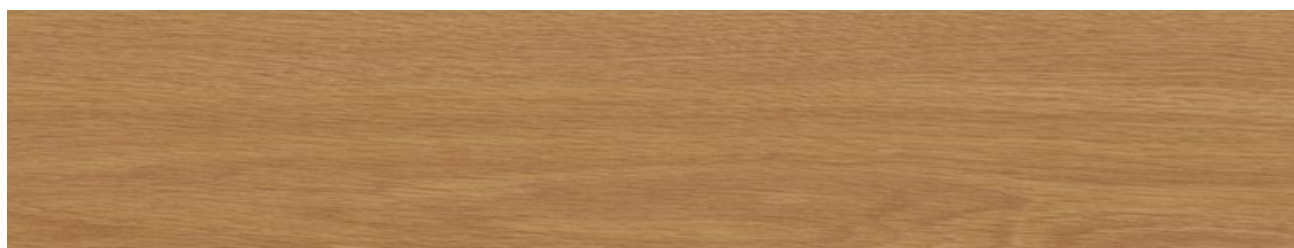

1661 oak · *rovere montano*

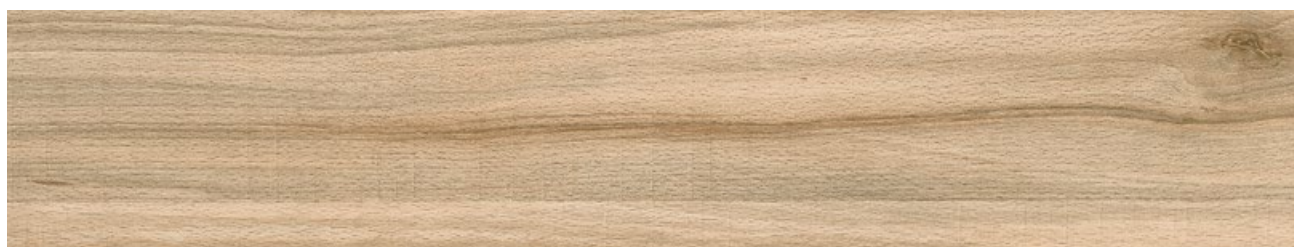

671 rustic beech · *faggio rustico*

Other types of antistatic HPL available on request *Altri tipi di laminato antistatico disponibili a richiesta.* · **The standard coverings used are all original Abet Walkprint finishing type SEI.** *I rivestimenti standard utilizzati sono tutti originali Abet Walkprint finitura SEI.*

ANTISTATIC HPL - STANDARD

available sizes *formato disponibile* 600 x 600 mm

thickness *spessore* 0,9 mm · other thickness on request *altri spessori a richiesta*

▼ SOFT COVERINGS

<<

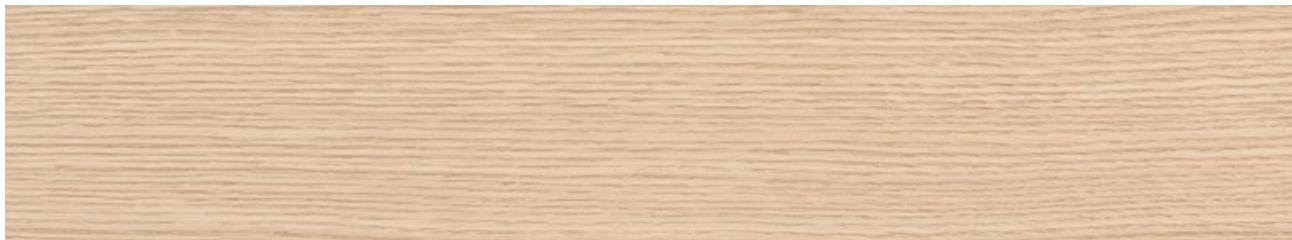

650 oak texas · *rovere texas*

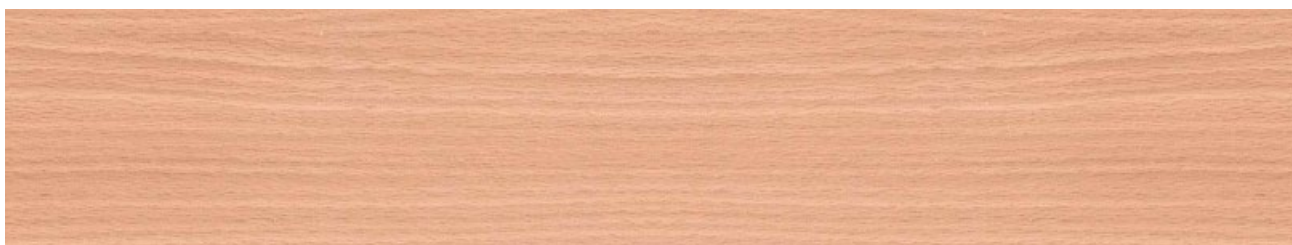

1666 beech · *faggio*



1611 maple · *acero*



1385 ash white · *bianco cenere*

Other types of antistatic HPL available on request *Altri tipi di laminato antistatico disponibili a richiesta.* · **The standard coverings used are all original Abet Walkprint finishing type SEI.** *I rivestimenti standard utilizzati sono tutti originali Abet Walkprint finitura SEI.*

ANTISTATIC PVC - MIPOLAM CLASSIC

available sizes *formato disponibile* 600 x 600 mm

thickness *spessore* 2,0 mm

 SOFT COVERINGS



0003 ivory



0010 azure



0120 borneo



0108 pepper



0002 platinum

Total Thickness	EN ISO 24346 (EN 428)	mm	2.0
Weight	EN ISO 23997 (EN 430)	g/sq.m	3300
Width/Length of Sheet	EN ISO 24341 (EN 426)	cm/lm	200/20
Tile size	EN ISO 24342 (EN 427)	mm	300 x 300* / 608 x 608
Number of tiles per package	-	-	50/20
CLASSIFICATION			
Norm/Product Specification	-	-	EN ISO 10581 (EN 649)
European classification	EN ISO 10874 (EN 685)	class	34-43
Fire rating	EN 13 501-1	class	Bfl-s1
Static electrical propensity	EN 1815	kV	< 2
PERFORMANCE			
Wear resistance	EN 660.2	mm ³	7.5
Wear Group	NF 189	group	M
Type Binder content	EN ISO 10581	type	II
Dimensional stability	EN ISO 23999 (EN 434)	%	sheet 0.40 tile 0.25
Residual indentation	EN ISO 24343-1 (EN 433)	mm	0.03
Castor Chair test (type W)	ISO 4918 (EN 425)	-	OK
Thermal Conductivity	EN ISO 10456 (EN 12524)	W/(m.K)	0.25
Colour Fastness	EN 20 105-B 02	degree	6
Surface Treatment	-	-	PUR
Chemical Products fastness	EN ISO 26987 (EN 423)	class	OK
ENVIRONMENT / INDOOR AIR QUALITY			
TVOC after 28 days	ISO 16000-6	µg/ m ³	< 10



DISSIPATIVE PVC - MIPOLAM ROBUST EL7 STATIC

available sizes *formato disponibile* 600 x 600 mm

thickness *spessore* 2,0 mm

 SOFT COVERINGS

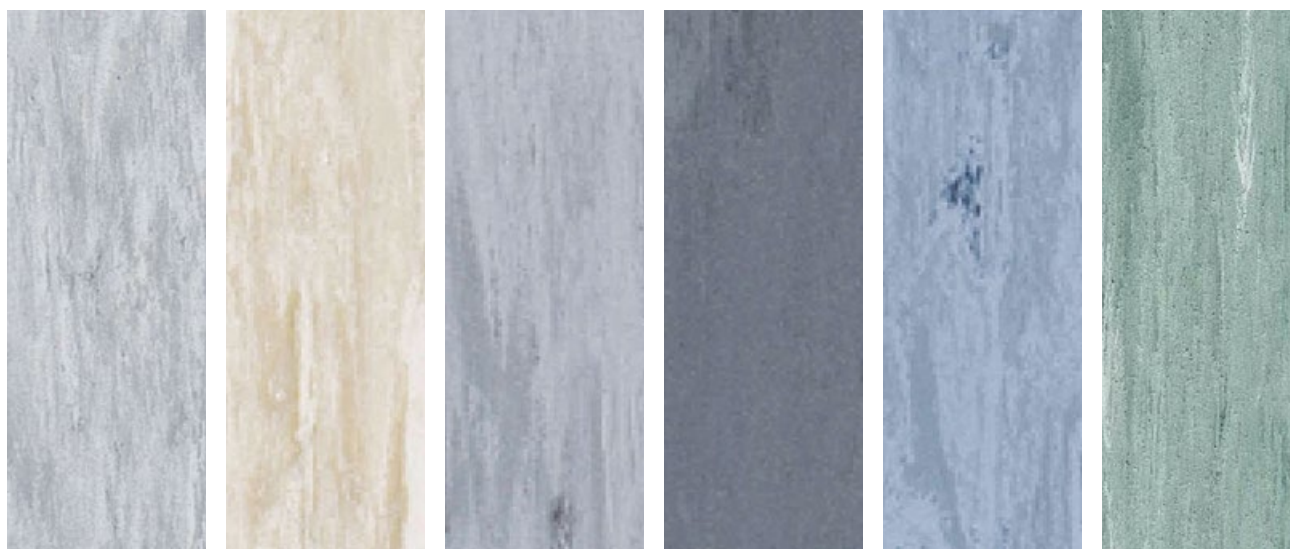

0002 platinum

0003 ivory

0005 steel

0013 pewter

0112 storm

0306 green

Total Thickness	EN ISO 24346 (EN 428)	mm	2.0
Weight	EN ISO 23997 (EN 430)	g/sq.m	3300
Width/Length of Sheet	EN ISO 24341 (EN 426)	cm/lm	200/20
Tile size	EN ISO 24342 (EN 427)	mm	608 x 608
Number of tiles per package	-	-	20
CLASSIFICATION			
Norm/Product Specification	-	-	EN ISO 10581 (EN 649)
European classification	EN ISO 10874 (EN 685)	class	34-43
Fire rating	EN 13 501-1	class	Bfl-s1
Electrical resistance (1)	EN 1081	Ohm	106 R t 10 8
Static electrical propensity	EN 1815	kV	< 2
PERFORMANCE			
Wear resistance	EN 660.2	mm ³	< 7.5
Wear Group	NF 189	group	M
Type Binder content	EN ISO 10581	type	II
Dimensional stability	EN ISO 23999 (EN 434)	%	sheet 0.40 tile 0.25
Residual indentation	EN ISO 24343-1 (EN 433)	mm	0.03
Castor Chair test (type W)	ISO 4918 (EN 425)	-	OK
Thermal Conductivity	EN ISO 10456 (EN 12524)	W/(m.K)	0.25
Colour Fastness	EN 20 105-B 02	degree	6
Surface Treatment	-	-	PUR
Chemical Products fastness	EN ISO 26987 (EN 423)	class	OK
ENVIRONMENT / INDOOR AIR QUALITY			
TVOC after 28 days	ISO 16000-6	µg/ m ³	< 10

(1) Measured before installation



CONDUCTIVE PVC - MIPOLAM TECHNIC EL5

available sizes *formato disponibile* 600 x 600 mm

thickness *spessore* 0,9 mm · other thickness on request *altri spessori a richiesta*

 SOFT COVERINGS

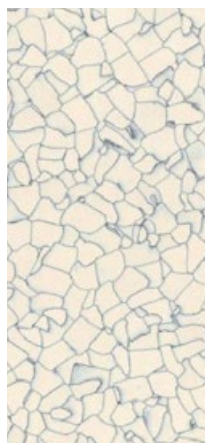

0635 white



0636 grey



0637 light blue



0638 blue



0639 green



0640 beige

Total Thickness	EN ISO 24346 (EN 428)	mm	2.0
	ASTM F386-02	inch	0.08
Weight	EN ISO 23997 (EN 430)	g/m ²	3800
Tile size	EN ISO 24342 (EN 427)	mm	608 x 608
Number of tiles per package	-	-	20
CLASSIFICATION			
Standard/Product Specification	-	-	EN ISO 10581 (EN 649)
European classification	EN ISO 10874 (EN 685)	class	34-43
Fire rating	EN 13 501-1	class	Bfl-s1
	EN 1081	Ohm	106 < Rt < 10 8
Electrical resistance (1)	IEC 61340 - 4 - 1	Ohm	< 10 9
	ANSI / ESD STM 7.1	Ohm	< 10 9
Static electrical propensity	EN 1815	kV	< 2
	IEC 61340 - 4 - 1	V	< 100 (2)
Protection against electrostatic discharges	ESD S20.20	-	OK
	IEC 61340 - 5 - 1	-	OK
PERFORMANCE			
Wear resistance	EN 660.2	mm ³	< 4.0
Wear Group	NF 189	group	P
Type Binder content	EN ISO 10581	type	II
Dimensional stability	EN ISO 23999 (EN 434)	%	< 0.25
Residual indentation	EN ISO 24343-1 (EN 433)	mm	0.03
Castor Chair test (type W)	ISO 4918 (EN 425)	-	OK
Thermal Conductivity	EN ISO 10456 (EN 12524)	W/(m.K)	0.25
Colour Fastness	EN 20 105-B 02	degree	> 6
Chemical Products fastness	EN ISO 26987 (EN 423)	class	OK
ENVIRONMENT / INDOOR AIR QUALITY			
TVOC after 28 days	ISO 16000-6	µg/ m ³	< 10

(1) Measured before installation (2) Measured with ESD shoes (ABEBA and Uvex)



Cable Management System

Sistema ispezionabile Cable Management

To provide easy an inspection of the technical areas, CBI Europe offers Cable Management System: raised access floors composed of BARE modular panels: calcium sulphate or chipboard, resting on standard steel structures. In addition to allowing the traceability of the technical areas, the panel 200 x 600 mm can be easily and repeatedly raised and rehoused for maintenance, interventions or changes. The version Corner Lock is available upon request, which has perforated panels on all four sides and is prepared for possible mounting by screws.

Per l'ispezionabilità degli impianti nei locali tecnici, CBI Europe propone Cable Management System, composto da pannelli modulari tipo BARE in solfato di calcio o conglomerato ligneo, poggianti sulle strutture standard in acciaio. Oltre a consentire la tracciabilità degli impianti, il pannello 200 x 600 mm può essere facilmente e ripetutamente sollevato e rialloggiato per manutenzioni, interventi o eventuali cambiamenti. Disponibile su richiesta la versione Corner Lock che prevede i pannelli forati sui quattro lati e predisposti per eventuale fissaggio con i piedini mediante viti autofilettanti.



INSPECTABILITY
ISPEZIONABILITÀ



QUICK INSTALLATION
INSTALLAZIONE RAPIDA



LOAD BEARING RESISTANCE
RESISTENZA AL CARICO



LIGHT WEIGHT
LEGGEREZZA

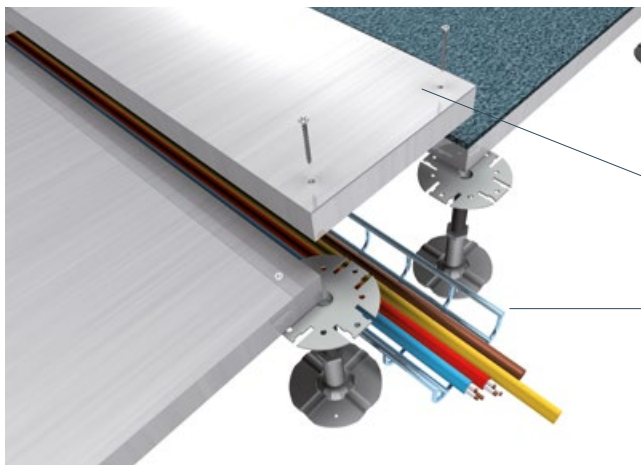

Cable Management System

woodcore panels · calcium sulphate panels
pannelli in conglomerato ligneo · solfato di calcio

cable passageway
passaggio cavi

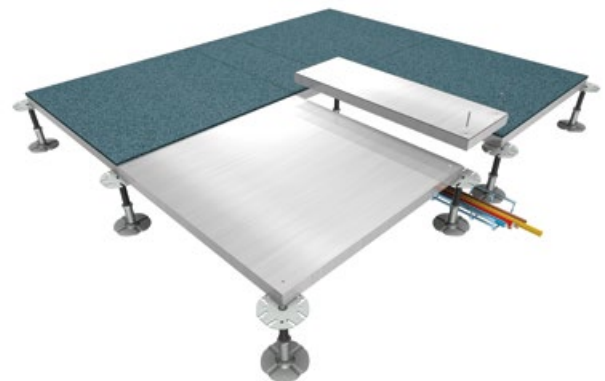

600 x 600 mm
200 x 200/600 mm

Metal Air steel panels

Pannelli in acciaio Metal Air

To provide easy ventilation and the safety of installations in data center, IT and technical areas or service areas, CBI Europe offers Metal Air Panel, system of raised access floors, which consists of modular panels in post-painted galvanized steel, resting on standard steel structures.

The Metal Air panels, with slotted or rounded holes, in addition to the normal benefits of overhead systems, guarantee maximum ventilation. Metal Air can be easily and repeatedly raised and rehoused for maintenance, interventions or changes. The panel is provided in four different versions, with round, slotted and perforated areas in different percentages

Per la ventilazione e la sicurezza degli impianti di data center, aree tecniche o informatiche e locali servizi: CBI Europe Metal Air, sistema di pavimenti tecnici sopraelevati composto da pannelli modulari in acciaio zincato postverniciato poggianti sulle strutture standard in acciaio.

I pannelli, forati o asolati, oltre ai vantaggi dei sistemi sopraelevati, garantiscono la massima ventilazione. Metal Air può essere facilmente e ripetutamente sollevato e rialloggiato per manutenzioni, interventi o eventuali cambiamenti.

Il pannello è disponibile con fori tondi o asolati in quattro versioni e con diverse percentuali di area forata.



**EUROCLASS
A1**



**INSPECTABILITY
ISPEZIONABILITÀ**



**QUICK INSTALLATION
INSTALLAZIONE RAPIDA**



**LOAD BEARING RESISTANCE
RESISTENZA AL CARICO**



Metal Air System

post-painted galvanized steel panels
pannelli in acciaio zincato post-verniciato

h 38 mm

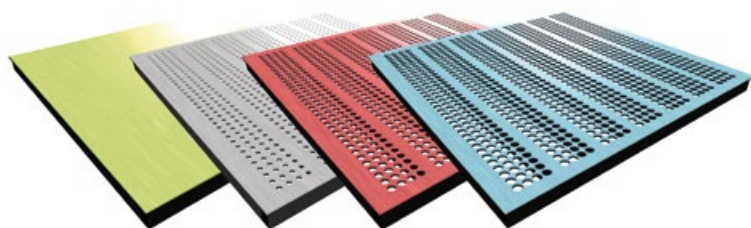

600 x 600 mm

The top of the panel is available in:

- > antistatic PVC
- > static dissipative PVC
- > conductive PVC

La finitura superiore del pannello

è disponibile in:

- > PVC antistatico
- > PVC statico dissipativo
- > PVC conduttivo

METAL AIR PANELS

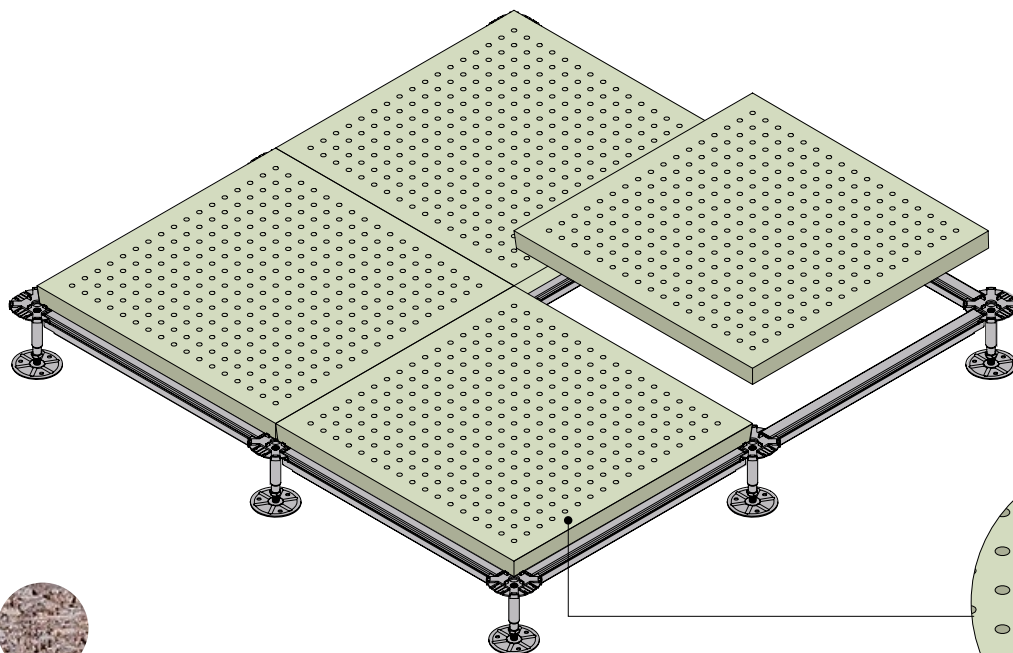

woodcore panels
pannelli in conglomerato ligneo

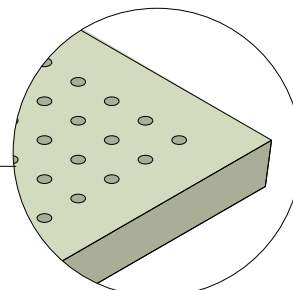

holes
fori

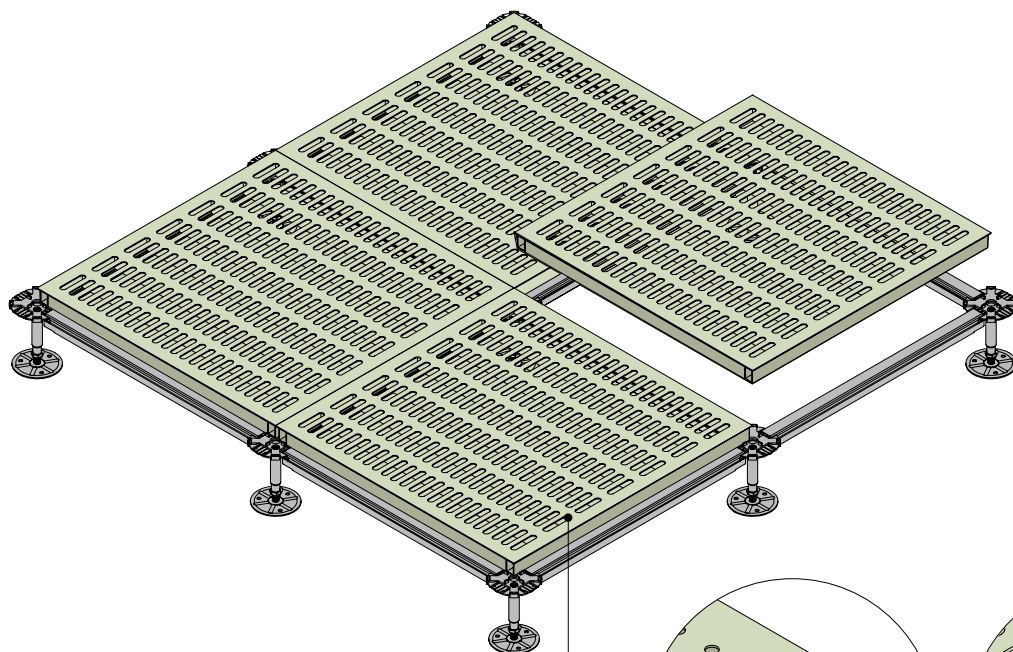

metal panels
pannelli in metallo

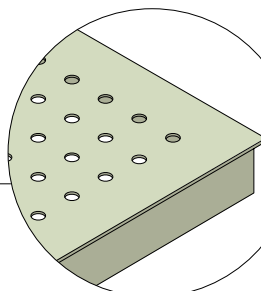

holes
fori

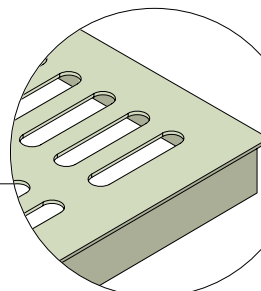

slots
asole

PERFORATIONS FORATURE

● perforation foratura ● slots asolatura

WOODCORE PANELS PANNELLI IN CONGLOMERATO LIGNEO

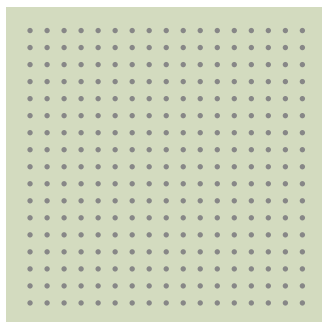

F01

holes fori ϕ 10 mm
nr. 289

perforated area
area perforata
6.0 %

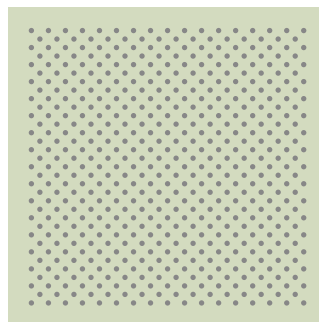

F02

holes fori ϕ 10 mm
nr. 545

perforated area
area perforata
12.0 %

METAL PANELS PANNELLI IN METALLO

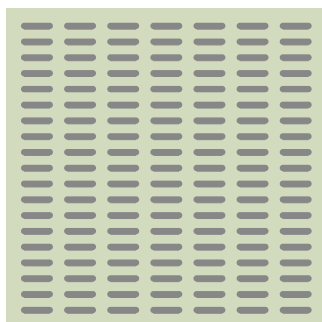

M01

slots asole 60x12 mm
nr. 133

perforated area
area perforata
25.0 %

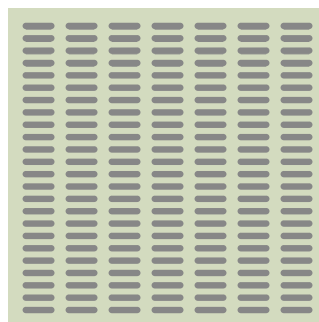

M02

slots asole 60x12 mm
nr. 168

perforated area
area perforata
32.0 %

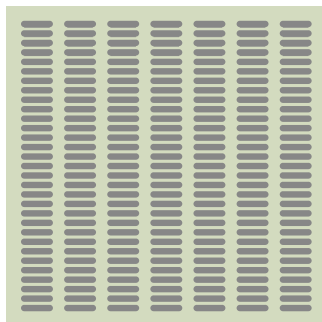

M03

slots asole 60x12 mm
nr. 217

perforated area
area perforata
42.0 %

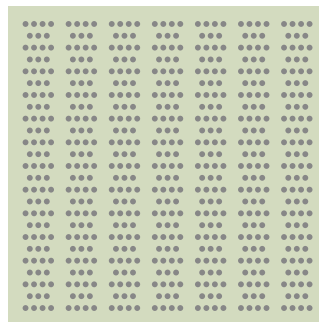

M04

holes fori ϕ 11 mm
nr. 616

perforated area
area perforata
16.0 %

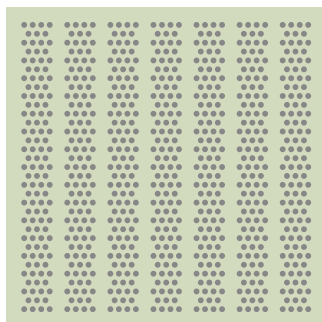

M05

holes fori ϕ 10 mm
nr. 812

perforated area
area perforata
22.0 %

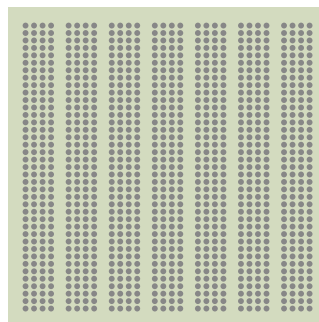

M06

holes fori ϕ 10 mm
nr. 1092

perforated area
area perforata
29.0 %

ACCESSORIES ACCESSORI

RAMPS AND CONNECTION STEPS RAMPE E GRADINI DI COLLEGAMENTO

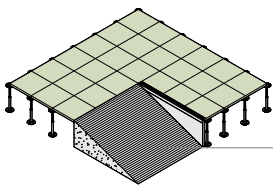

*mdf, connection step with anti-slip black rubber
*rampa di collegamento in mdf con gomma millerighe antiscivolo

R/RAC

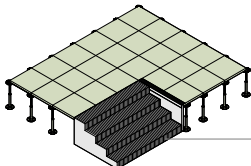

*mdf, connection step with anti-slip black rubber
*rampa di collegamento in mdf con gomma millerighe antiscivolo

G/Gan

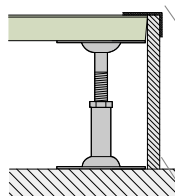

A/ALL
extruded aluminium molding
angolare antiscivolo in alluminio
L 3400 x 40 x 25 mm

● 436 grey

FTN/12
vertical upstand
fascia di tamponamento verticale
thickness 12 mm

● 436 grey ● 421 black

○ 422 white

*other ramp finishes available on request: HPL, PVC, linoleum · *altre finiture rampa disponibili su richiesta: HPL laminato, PVC vinile, linoleum

PERFORATED PANEL PANNELLO FORATO

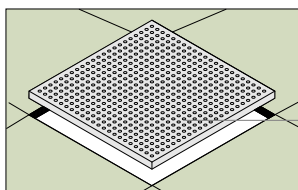

perforated panel for ventilation
pannello forato per areazione

AF1

AF2

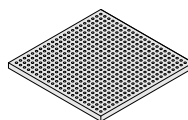

AF1

AF2

600 x 600 mm
AF1 holes \varnothing 8 mm $S=1.45 \text{ dm}^2$ -20%
/ holes \varnothing 10 mm $S=2.26 \text{ dm}^2$ -15%
AF2 holes \varnothing 8 mm $S=2.72 \text{ dm}^2$ -20%
/ holes \varnothing 10 mm $S=4.27 \text{ dm}^2$ -15%

ALUMINIUM VENTILATION GRID GRIGLIA DI VENTILAZIONE

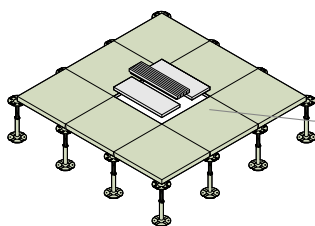

aluminium ventilation grid
with dumper for air regulation
griglia di ventilazione comprensiva
di dispositivo taratura del flusso

GRS/150

GRS/300

GRS/600

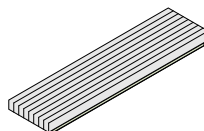

GRS/150

GRS/300

GRS/600

600 x 150/300/600 mm

ELECTRICAL OUTLET BOX TORRETTA A SCOMPARSA

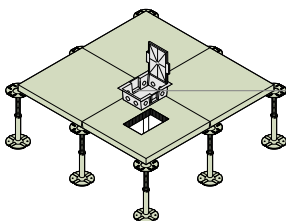

electrical outlet box
torretta a scomparsa
per impianto elettrico

TS/8

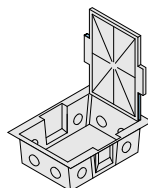

TS/8

*electrical outlet box, 8 partitions
*torretta a scomparsa per impianto
elettrico, 8 moduli

*available on request 16 modules version
*disponibile su richiesta versione 16 moduli

PERIMETRAL GASKET FOR FIXING *GUARNIZIONE PERIMETRALE ADESIVA*

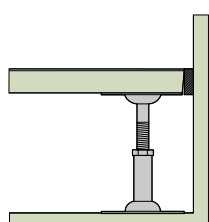

*perimetral gasket for fixing
*guarnizione perimetrale adesiva

X105



X105/30
X105/40

X105/30 : 5x30 mm lenght 28 ml/rool
X105/40 : 5x40 mmlenght 28 ml/rool

*one-component polyuretane based foam available on request instead of the perimetral seal

*in sostituzione della guarnizione perimetrale, è disponibile su richiesta schiuma poliuretana monocomponente

SKIRTING *BATTISCOPIA*

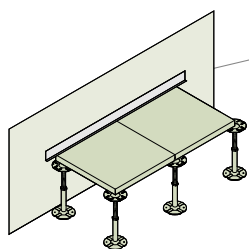

perimeter skirting
battiscopa perimetrale

BT/PVC

○ 422 white ● 436 grey
● 421 black

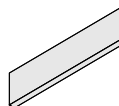

BT/PVC

60/80 x 5 x 3000 mm

SELF-ADHESIVE ALUMINIUM *ADESIVO IN ALLUMINIO*

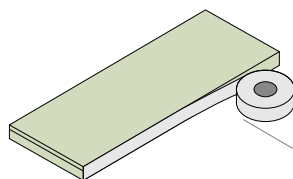

self-adhesive aluminium tape
euro class A1 incombustibile
adesivo in alluminio
euro classe A1 incombustibile

SA/ALL
SA/ALL.1

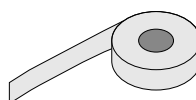

SA/ALL/30
SA/ALL/40

SA/ALL/30 : 30 mm - lenght 50 ml/rool
SA/ALL/40 : 40 mm - lenght 50 ml/rool

INCIDENCE INCIDENZA

PANEL PANNELLO

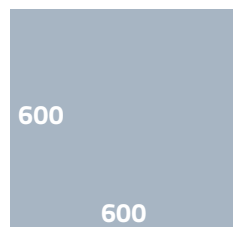

The standard 600 x 600 mm format effectively optimises usage.

Il formato standard 600 x 600 mm consente una efficace ottimizzazione di impiego.

incidence incidenza

surface superficie	panel pannello	pedestal pedino	stringer traversa
25 mq	2.78 pcs/mq	4,0 pcs/mq	7,2 pcs/mq
50 mq	2.78 pcs/mq	3,5 pcs/mq	6,4 pcs/mq
100 mq	2.78 pcs/mq	3,3 pcs/mq	6,2 pcs/mq
200 mq	2.78 pcs/mq	3,2 pcs/mq	6,1 pcs/mq
400 mq	2.78 pcs/mq	3,2 pcs/mq	5,9 pcs/mq
1000 mq	2.78 pcs/mq	2,8 pcs/mq	5,6 pcs/mq

The average incidence is theoretic. It changes according to the dimension and shape of the space.

Le incidenze riportate sono teoriche in quanto variano in relazione alle dimensioni ed alla conformazione dei locali.

PEDESTAL PIEDINO

pcs/box pcs/confezione

CBIF12	height altezza	packaging imballo	CBIF16	height altezza	packaging imballo	CR	height altezza	packaging imballo
CBIO3F12	45/65 mm	75 pcs	CBIO1F16	26/35 mm	100 pcs	CR00F16	120/200 mm	50 pcs
CBIO4F12	61/90 mm	60 pcs	CBIO2F16	32/48 mm	100 pcs	CR01F16	200/350 mm	30 pcs
CBIO5F12	83/130 mm	60 pcs	CBIO3F16	45/65 mm	75 pcs	CR02F16	350/550 mm	30 pcs
CBIO6F12	120/200 mm	50 pcs	CBIO4F16	61/90 mm	60 pcs	CR03F18	550/800 mm	15 pcs
CBIO7F12	170/290 mm	45 pcs	CBIO5F16	83/130 mm	60 pcs	CR04F20	800/1050 mm	15 pcs
			CBIO6F16	120/200 mm	50 pcs	CR05F20	1050/1300 mm	10 pcs
			CBIO7F16	170/290 mm	45 pcs			
			CBIO8F16	250/390 mm	30 pcs			
			CBIO9F16	350/490 mm	20 pcs			
			CBIO10F16	450/650 mm	20 pcs			

IF Pedestal are sold individually.

I piedini del sistema IF sono venduti al pezzo.

recommendations for installation *raccomandazioni per l'installazione*

care and installation

Premises where the floor is stored or installed must have a dry climate and completed window and floor frames; the temperature must be maintained between 5 and 35 °C and the humidity between 40% and 75%.

The floor should be installed 60 days after the concrete casting and 30 days from completion of internal finishings.

The foundation must be dry, smooth and clean; if a slab is used it is advisable to adopt a selflevelling floor foundation. It is advisable to treat the floor foundation with an anti-dust paint.

The distribution of the equipment must observe the technical requirements of the floor.

The floor has to be installed only after completion of internal equipment and finishing. Only the installer can walk on the floor during installation. As soon as installation is completed and before any other application is made, the floor has to be tested.

use and maintenance

When moving considerable loads over the floor, use trolleys and non-flexible panels between the floor and the wheels.

When laying or removing the panels, use suitable tools.

Do not damage or move the gasket of the pede-stals and of the stringers. Removed panels must be mounted again in the original position.

For any intervention remove the fewer panels than possible. Floor can be cleaned with a damp cloth; do not use water or cleaning agents directly and be careful when near an electric cable system. Do not wash plenum with water.

Do not use alkaline detergents, soda, soaps, solvents, pumice, sandpaper, and any kind of abrasive.

Before waxing the floor, make preliminary test on a limited floor surface. If the floor has particular electrical characteristics, use an electrical compatible wax.

custodia e installazione

I locali in cui dovrà essere immagazzinato o installato il pavimento sopraelevato, dovranno essere asciutti e con serramenti completati; la temperatura dovrà essere compresa tra i 5 e i 35 °C e l'umidità relativa tra il 40 ed il 75%. Prima di installare il pavimento le opere murarie dovranno essere terminate da almeno 60 giorni e le opere di finitura a umido da almeno 30 giorni.

Il sottofondo dovrà essere asciutto, liscio e pulito; in caso di soletta a getto è consigliabile prevedere l'adozione di un sottofondo autolivellante. È consigliabile un trattamento di verniciatura antipolvere del sottofondo. La distribuzione degli impianti dovrà rispettare lamodularità del pavimento sopraelevato e dovrà tenere conto degli ingombri dello stesso. Il montaggio del pavimento sopraelevato dovrà essere effettuato solo quando saranno completati tutti gli impianti e le finiture interne.

Nessuno, a eccezione degli installatori, dovrà camminare sopra il pavimento durante il montaggio.

Il pavimento sopraelevato dovrà essere collaudato e consegnato non appena ultimata l'installazione, prima dell'applicazione di eventuali cere protettive e dell'intervento degli impiantisti.

uso e manutenzione

Utilizzare sempre carrelli per spostare carichi notevoli al di sopra del pavimento, interponendo tra le ruote ed il piano di calpestio dei pannelli rigidi al fine di ripartirne i carichi. La rimozione e la posa dei pannelli deve essere eseguita utilizzando tassativamente gli appositi attrezzi di sollevamento. Fare attenzione a non danneggiare o spostare le guarnizioni di tenuta dei piedini e delle traverse; in caso di danneggiamento provvedere alla sostituzione. I pannelli rimossi dovranno essere ricollocati nella posizione originaria.

Dovendo smontare diversi pannelli, evitare la formazione di "isole" o "canali" togliendo solo la minima quantità necessaria all'intervento. Per la pulizia non usare acqua o detergenti liquidi direttamente sul pavimento sopraelevato; utilizzare panni inumiditi e ben strizzati e porre molta attenzione nelle vicinanze dei sistemi di distribuzione elettrica; non usare acqua per la pulizia del plenum.

Non usare detersivi alcalini, soda, saponi, solventi, pomice, carta vetrata ed abrasivi vari.

Dovendo cerare il pavimento, è consigliabile eseguire una prova preliminare su una porzione limitata dello stesso.

Nel caso debba essere cerato un pavimento con particolari caratteristiche elettriche, utilizzare cere elettricamente compatibili.



CE MARKING



ISO 9001
QUALITY MANAGEMENT SYSTEM



EPD ENVIRONMENTAL
PRODUCT DECLARATION®



FSC® CERTIFICATION
CERTIFICAZIONE FSC®



EUROFINS
INDOOR AIR COMFORT GOLD



LEED LEADERSHIP IN ENERGY
AND ENVIRONMENTAL DESIGN

Ogni attenzione è stata riservata alla compilazione di questi documenti prima della stampa. Tuttavia, a causa della continua evoluzione tecnologica ed essendo costantemente impegnati sul fronte dello sviluppo e del miglioramento della nostra gamma di prodotti, ci riserviamo il diritto di modificare senza preavviso le relative specifiche tecniche.

Great care has been taken in the drafting of these document before going to print. Nonetheless, owing to the continuous technological change and our ongoing commitment to develop and improve our range of products, we reserve the right to develop and improve our range of products and the right to modify the specifications of any product without prior notice.

Tutti i nostri prodotti sono realizzati in Italia.
All products are entirely made in Italy.



CBI EUROPE Via Mons. A.O. Romero, 14 · 60027 Osimo (AN) Italy
T +39 071 71 08 688 · fax +39 071 71 08 63 · info@cbi-europe.com · www.cbi-europe.com